

# **H&S**

## **Front and Rear Self-Unloading Forage Box H D 7+4**



### **WARNING**

**READ AND UNDERSTAND THIS MANUAL  
BEFORE OPERATING THIS EQUIPMENT.**

**UNSAFE OPERATION OR MAINTENANCE OF THIS EQUIPMENT CAN RESULT IN  
SERIOUS INJURY OR DEATH.**

## **OPERATOR'S MANUAL and PARTS LIST**

3-8-2002

Manufactured By

**H&S MANUFACTURING CO., INC.**

P.O. BOX 768 • (715) 387-3414 FAX (715) 384-5463

MARSHFIELD, WISCONSIN 54449

# H&S FRONT & REAR UNLOAD H D 7+4 FORAGE BOX CONTENTS

Warranty & Warranty Registration Card . . . . .	1-2
Dealer Pre-Delivery & Delivery Checklist . . . . .	3
Be Alert Symbol . . . . .	5
Explanation of Safety Signs . . . . .	6
Danger - Warning Decals . . . . .	7-8
Warning - Owner Must Read and Understand . . . . .	9
Warning - Emergency Stop-Field Operation-Front Unload . . . . .	10-11
Operation & Adjustments . . . . .	12-16
Lubrication Guide . . . . .	16-17
Rear Door Locks-Field Operation - Rear Unload . . . . .	18-19
Danger - Entering Forage Box . . . . .	20
PTO Assembly - Optional Fold Down Extension - Optional Hydraulic Drive . . . . .	21
Decal Location & Identification . . . . .	22-23
Instructions for Ordering Parts - About Improvements . . . . .	24
Figure 1 - Light Assembly - Wiring Code . . . . .	25
Figure 2 - Housing Components for Unit . . . . .	26-27
Figure 3 - Beaters & Main Apron Drive . . . . .	28-29
Figure 4 - Cross Apron & Drive Assembly . . . . .	30-31
Figure 5 - Shields, Beater Clutch-Belt Drive . . . . .	32-33
Figure 6 - Rear Unload Assembly . . . . .	34-35
Figure 7 - Box Components . . . . .	36-37
Figure 8 - Bevel Gearbox . . . . .	38-39
Figure 9 - Worm Gearbox . . . . .	40-41
Figure 10 - PTO Parts . . . . .	42
Figure 11 - Tie Down Kit . . . . .	43
Figure 12 - Cross Conveyor Clutch - Belt Drive . . . . .	44-45
Figure 13 - Optional 12" Fold-Down Extension . . . . .	46-47
Figure 14 - Optional Hydraulic Drive . . . . .	48
SPECIFICATIONS . . . . .	INSIDE BACK COVER

# WARRANTY

## Mr. Owner: Before Operating—Read and Understand Operating and Safety Instructions

H&S Manufacturing Co., Inc. truly believes you have made a wise choice and a sound and lasting investment. Many years of development have made available these quality machines to assure you the performance and reliability you need. **We ask you to read the following agreement and warranty as this unit is subject to this warranty and agreement and no other.**

### THE H&S WARRANTY

H&S Manufacturing Co., Inc. warrants this unit to be free from breakage or malfunctions due to defects in material and or workmanship for a period of one year from date of original sale on parts and limited labor, two years parts. Should such breakage or malfunction occur within warranty period the liability of H&S, its employees, agents, authorized distributors, and dealers (Hereinafter collectively referred to as sellers) is hereby expressly limited to repairing or, at its option, replacing free of charge at its factory, any such defective part or parts. Sellers liability is further expressly limited with respect to components manufactured by others, such as universal joints, bearings, detachable link and roller chains, tires, belts or trade accessories, to the extent of such warranties as are extended thereon to sellers by these manufacturers.

**THIS WARRANTY IS IN LIEU OF ALL OTHER WARRANTIES, EXPRESSED OR IMPLIED, INCLUDING BUT NOT LIMITED TO WARRANTIES OF MERCHANTABILITY OR APPLICABLE FOR ANY PARTICULAR PURPOSE, AND THE OBLIGATION AND LIABILITY OF SELLERS UNDER THIS WARRANTY, DOES NOT EXTEND TO LOSS OF CROPS, LOSS BECAUSE OF DELAY IN HARVESTING OR ANY EXPENSE OR LOSS INCURRED FOR LABOR, SUPPLIES, SUBSTITUTE MACHINERY OR RENTAL MACHINERY, TRANSPORTATION OR OTHER CHARGES, OR ANY OTHER INDIRECT OR CONSEQUENTIAL LOSS.**

H&S Mfg. Co., Inc. reserves the right to make changes in design and components or material or to utilize available materials which it deems satisfactory, in order to improve its products. Also H&S reserves the right to make changes in the construction or design of any parts without any incurring obligations to install these improvements or changes on previously delivered units.

This warranty shall be void if any part or parts not manufactured or supplied by H&S are used either in servicing and maintaining the unit, and sellers obligation to repair or replace parts are then voided. This warranty shall be void if in the judgement of H&S, repairs are made in such a manner to affect this unit in a materially adverse manner or if this unit is operated unsafely or while in a state of disrepair.

The terms and conditions of this warranty cannot be altered, modified, or waived by any seller without the expressed, written consent of an officer of H&S Mfg. Co., Inc.

### NOTICE

H&S Manufacturing Co., Inc. disclaims any liability for the operation of the equipment with the safety guards removed or modified. The nature of this product requires that it be operated in a safe way only, and in good repair by qualified persons. Each purchaser, through the process of purchasing this equipment, agrees with H&S Manufacturing Co., Inc. to operate it in a safe manner and in accordance with applicable state and federal laws and agrees to indemnify and hold harmless H&S Manufacturing Co., Inc. from any loss to any person or persons caused by purchaser's failure to do so. Each purchaser further agrees to bring to the attention this notice to each subsequent purchaser, and to obtain his agreement thereto as a condition of resale or transfer.

### IMPORTANT

**TO MAKE THIS WARRANTY EFFECTIVE, THE OWNERS WARRANTY REGISTRATION FURNISHED WITH EACH MACHINE MUST BE FILLED OUT AND SENT TO H&S MANUFACTURING CO., INC. IF PURCHASER DOES NOT ACCEPT THIS WARRANTY AND AGREEMENT, HE MAY RESCIND THE SALE BY NOTIFYING ANY OF THE SELLERS IN WRITING OF THAT FACT WITHIN TEN DAYS FROM DATE OF SALE AND/OR PRIOR TO ANY USE OF THE EQUIPMENT WITHIN THIS 10 DAYS.**

2/97

**FILL OUT AND MAIL  
IMMEDIATELY TO MAKE  
WARRANTY EFFECTIVE**



### WARRANTY REGISTRATION

Date of Purchase \_\_\_\_\_

Purchaser \_\_\_\_\_ Address \_\_\_\_\_

City \_\_\_\_\_ State \_\_\_\_\_ Zip \_\_\_\_\_

Product \_\_\_\_\_ Model # \_\_\_\_\_ Serial # \_\_\_\_\_

Dealer \_\_\_\_\_ Address \_\_\_\_\_

City \_\_\_\_\_ State \_\_\_\_\_ Zip \_\_\_\_\_

\_\_\_\_\_  
Signature of original buyer

**IMPORTANT!**

Tear on dotted line, provide the information requested on the card. The H&S Warranty is valid **only** after this card is received and recorded at H&S Mfg. Co. Mail at once. No postage is required in the U.S.A.

This Is Your Warranty Card  
Please Fill Out  
And Mail Immediately



NO POSTAGE  
NECESSARY  
IF MAILED  
IN THE  
UNITED STATES

**BUSINESS REPLY MAIL**

FIRST CLASS MAIL Permit No. 195 Marshfield, WI 54449

POSTAGE WILL BE PAID BY ADDRESSEE

**H&S Manufacturing Co., Inc.**

PO Box 768  
Marshfield WI 54449-9963

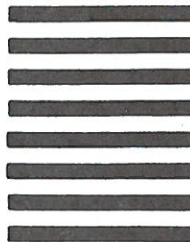

**AFTER COMPLETION, DEALER SHOULD REMOVE AND RETAIN FOR RECORDS**

**H&S  
DEALER PRE-DELIVERY CHECK LIST**

After the Self-Unloading Box has been completely set-up, check to be certain it is in correct running order before delivering to the customer. The following is a list of points to inspect. Check off each item as you have made the proper adjustments and found the item operating satisfactorily.

- PTO shields turn freely.
- All shields and guards are in place and fastened.
- All grease fittings have been lubricated and gear boxes filled to proper level – See lubrication guide in this manual.
- All mechanisms are operating trouble free.
- All roller chains are at proper tension.
- Apron chains are adjusted properly.
- All bolts and fasteners are tight.
- 2 extra shear bolts are provided.
- All decals are in place and legible.

(Dealer's Name)	Model Number
(Signature of Pre-Delivery Inspector)	Serial Number
(Signature of Pre-Delivery Inspector)	(Inspection Date)

**DEALER DELIVERY CHECK LIST**

This check list that follows is an important reminder of valuable information that should be passed on to the customer at the time this Self-Unloading Forage Box is delivered.

Check off each item as you explain it to the customer.

This pre-delivery check list, when properly filled out and signed assures the customer that the pre-delivery service was satisfactorily performed.

- Explain to the customer that the pre-delivery inspection was made.
- Explain to the customer all the safety precautions they must exercise when operating this unit.
- Explain recommended loads for different types of materials.
- Explain to customer that regular lubrication is required for proper operation and long life of machine. Show customer the lubrication section of Owner's Manual.
- Give the customer Owner's Manual and make sure he reads and understands all operating and service instructions.
- Record Serial Number on Page 24 of this Manual.
- Have customer sign a completed "Warranty Registration," and mail it promptly.

Date Delivered \_\_\_\_\_ Dealer's Name \_\_\_\_\_  
 By \_\_\_\_\_  
 \_\_\_\_\_  
 Signature of Original Buyer

Note: Warranty is not valid until warranty card is completed and returned to H&S Mfg. Co., Inc.

Remove Dealers File Copy At Perforation



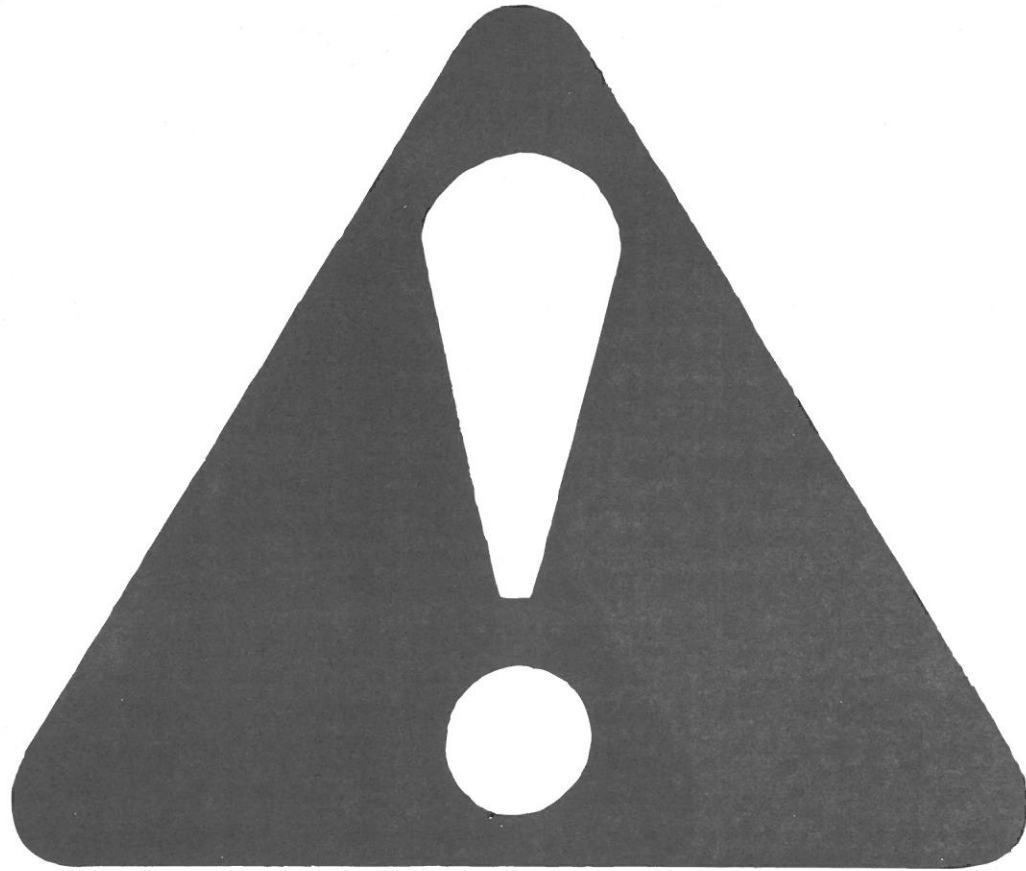

**BE  
ALERT!**

**YOUR SAFETY  
IS INVOLVED.**

THIS SYMBOL IS USED THROUGHOUT THIS BOOK WHENEVER YOUR PERSONAL SAFETY IS INVOLVED. TAKE TIME TO BE CAREFUL. REMEMBER: THE CAREFUL OPERATOR IS THE BEST OPERATOR. MOST ACCIDENTS ARE CAUSED BY HUMAN ERROR. CERTAIN PRECAUTIONS MUST BE OBSERVED TO PREVENT THE POSSIBILITY OF INJURY OR DAMAGE.

**TRACTORS**

This operators' manual uses the term "Tractor" when identifying the power source.

**H&S MANUFACTURING CO. INC.**

## RECOGNIZE SAFETY INFORMATION

This is the safety-alert symbol. When you see this symbol on your machine or in this manual, be alert to the potential for personal injury.

Follow recommended precautions and safe operating practices.

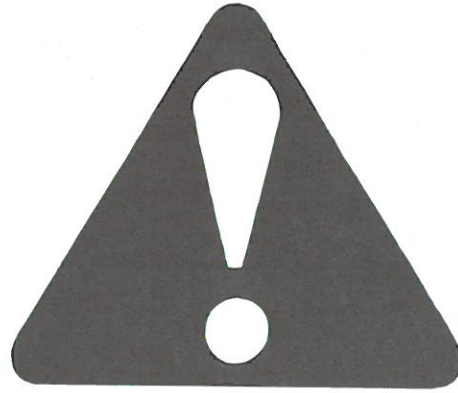

## UNDERSTAND SIGNAL WORDS

A signal word—DANGER, WARNING, or CAUTION—is used with the safety-alert symbol. DANGER identifies the most serious hazards.

Safety signs with signal word DANGER or WARNING are typically near specific hazards.

General precautions are listed on CAUTION safety signs.



**WARNING**



**CAUTION**



## FOLLOW SAFETY INSTRUCTIONS

Carefully read all safety messages in this manual, and all safety signs on your machine. Follow all recommended precautions and safe operating procedures.

Keep signs in good condition. Immediately replace any missing or damaged signs.



**! DANGER**



STAY CLEAR OF BEATER AND/OR CROSS CONVEYOR IF POWER SOURCE OR PTO IS RUNNING

FAILURE TO HEED THIS WARNING MAY RESULT IN PERSONAL INJURY OR DEATH

KEEP CLOTHING, YOURSELF AND OTHERS WELL CLEAR.

1494H

**! WARNING!**



KEEP CHILDREN AWAY AT ALL TIMES!

2495

**! DANGER**



ROTATING DRIVELINE CONTACT CAN CAUSE DEATH KEEP AWAY!

DO NOT OPERATE WITHOUT-

- ALL DRIVELINE, TRACTOR AND EQUIPMENT SHIELDS IN PLACE.
- DRIVELINES SECURELY ATTACHED AT BOTH ENDS.
- DRIVELINE SHIELDS THAT TURN FREELY ON DRIVELINE.

1494L

**! DANGER**



ROTATING DRIVELINE CONTACT CAN CAUSE DEATH KEEP AWAY!

DO NOT OPERATE WITHOUT-

- ALL DRIVELINE GUARDS, TRACTOR AND EQUIPMENT SHIELDS IN PLACE
- DRIVELINES SECURELY ATTACHED AT BOTH ENDS
- DRIVELINE GUARDS THAT TURN FREELY ON DRIVELINE

**! DANGER**



MAINTAIN SAFE CLEARANCE FROM ELECTRIC POWER LINES AND AVOID CONTACT WITH ANY ELECTRICALLY CHARGED CONDUCTOR.

CONTACT WITH ELECTRIC POWER SOURCES CAN RESULT IN ELECTRICAL SHOCK OR ELECTROCUTION.

FAILURE TO HEED THIS WARNING MAY RESULT IN SERIOUS INJURY OR DEATH.

1494P

**! WARNING**

WHEN OPERATING FORAGE BOX AS A REAR UNLOAD, OPERATOR SHOULD REMAIN IN TRACTOR SEAT AND KEEP ALL OTHERS WELL CLEAR.

EMERGENCY STOP DOES NOT STOP FORAGE BOX WHEN BEING OPERATED AS A REAR UNLOAD.

1494Q

**! DANGER**

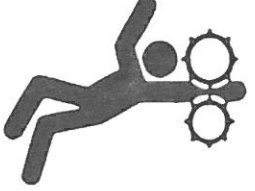

KEEP OUT

DISENGAGE ALL POWER AND SHUT OFF TRACTOR ENGINE BEFORE ATTEMPTING TO ENTER OR CLEAN FORAGE BOX FAILURE TO HEED THIS WARNING MAY RESULT IN PERSONAL INJURY OR DEATH

1494I



**! DANGER**

NEVER ENTER FORAGE BOX UNLESS THE FOLLOWING SAFETY PRECAUTIONS ARE FOLLOWED.

1494F



**! WARNING**

EMERGENCY STOP CABLE FUNCTIONS ONLY WHEN FORAGE BOX IS BEING OPERATED AS A FRONT UNLOAD

1494O



**! WARNING**

DO NOT GO NEAR LEAKS

- High pressure oil easily punctures skin causing serious injury, gangrene or death.
- If injured, seek emergency medical help. Immediate surgery is required to remove oil.
- Do not use finger or skin to check for leaks.
- Lower load or relieve hydraulic pressure before loosening fittings.

11599

# **WARNING**

**TO PREVENT SERIOUS INJURY OR DEATH  
NEVER OPERATE THIS UNIT UNLESS  
EMERGENCY STOP FUNCTIONS PROPERLY.** 5896C

## **WARNING**

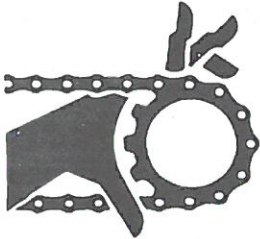

**DO NOT  
REMOVE  
SHIELDS**

**MOVING  
PARTS  
INSIDE**

1494K

## **WARNING** **HELP AVOID INJURY**

- READ & UNDERSTAND THE OPERATORS MANUAL PROVIDED WITH THIS MACHINE. IF MISPLACED CALL H & S MANUFACTURING AT: 715-387-3414 WITH MODEL AND SERIAL NUMBER.
- UNDERSTAND ALL SAFETY WARNINGS AND FUNCTION OF CONTROLS.
- KEEP SAFETY DEVICES IN PLACE AND WORKING.
- KEEP YOURSELF AND OTHERS WELL CLEAR OF MOVING PARTS.
- DISCONNECT ALL POWER BEFORE SERVICING OR CLEANING THIS MACHINE.

5896A

## **WARNING**

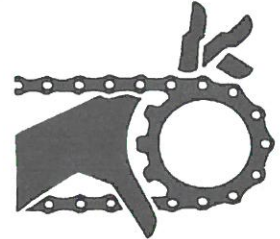

**DO NOT CLEAN  
OR WORK ON THIS  
MACHINE WITHOUT  
FIRST DISENGAGING  
POWER AND  
SHUTTING OFF  
TRACTOR ENGINE.**

1494J

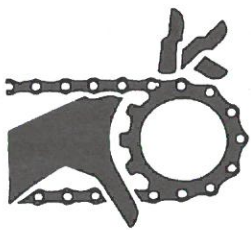

1494B

 **WARNING**

**DO NOT  
REMOVE  
SHIELDS**

**MOVING PARTS  
INSIDE**



1494E

 **WARNING**

**DO NOT INSTALL  
BOLSTER PLATES ONTO  
BOX STRINGER  
WITHOUT BLOCKING  
BOX IF BOX IS  
RAISED UP**

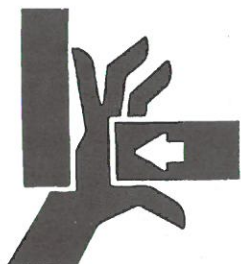

1494C

 **WARNING**

**STAY CLEAR  
MOVING PARTS  
UNDER THIS  
AREA**



1494A

 **WARNING**

**DO NOT OPERATE  
THIS EQUIPMENT  
IF THIS DECAL IS  
EXPOSED.  
REPLACE SAFETY  
SHIELDS.**

# H&S H D 7+4 FRONT & REAR UNLOADING FORAGE BOX



## WARNING

### TO PREVENT SERIOUS INJURY OR DEATH

BEFORE YOU ATTEMPT TO OPERATE THIS EQUIPMENT, READ AND STUDY THE FOLLOWING INFORMATION. IN ADDITION, MAKE SURE THAT EVERY INDIVIDUAL WHO OPERATES OR WORKS WITH THIS EQUIPMENT, WHETHER FAMILY MEMBER OR EMPLOYEE, IS FAMILIAR WITH THESE SAFETY PRECAUTIONS. KNOW HOW TO STOP UNLOADING MECHANISM BEFORE STARTING IT.

EMERGENCY STOP DOES NOT STOP FORAGE BOX WHEN BEING OPERATED AS A REAR UNLOAD.

If the machine becomes clogged, disengage the PTO or tractor hydraulics. Stop the tractor engine and allow all mechanisms to stop before cleaning or working on the machine.

**DO NOT** attempt to perform maintenance or repair with tractor running and PTO or tractor hydraulics hooked up.

**DO NOT** step up on machine at any time.

**NEVER** manually feed material into the beaters.

**DO NOT** allow minors to operate or be near the machine.

**DO NOT ALLOW PERSONNEL OTHER THAN THE QUALIFIED OPERATOR NEAR THE MACHINE.**

**BEFORE** starting tractor, be sure PTO shields turn freely and PTO is securely locked to tractor.

**DO NOT** clean, adjust, or lubricate the machine when any part is in operation.

**CHECK** frequently to be assured that the emergency stop mechanism is in proper operating condition.

**KEEP** hands, feet, and clothing away from beaters when they are revolving.

**LOOSE** or floppy clothing should not be worn by the operator.

**BE SURE** the machine is clear of people, tools, and other objects before engaging PTO or tractor hydraulics.

**STAY CLEAR** of hydraulic lines and fittings. They may be under extreme pressure or heat.

**DO NOT** step over power take off shaft. Stay clear of PTO at all times.

**NEVER** start forage box until all guards and safety shields are secured in place.

**NEVER** put hand in cross conveyor outlet openings while tractor is running.

**CAUTION** – Beware of low electrical wires.

**NEVER** hook up 1000 RPM tractor to the forage box.

**STAY CLEAR** of rear of forage box at all times.

H&S Mfg. Co. always takes the operator and his safety into consideration and guards exposed moving parts for his protection. However, some areas cannot be guarded or shielded in order to assure proper operation. In addition, the operators manual and decals on the machine itself warn you of further danger and should be read and observed closely.

**Study The Above Safety Rules**

**ATTENTION - BE ALERT - YOUR SAFETY IS INVOLVED**



# WARNING

**TO PREVENT SERIOUS INJURY OR DEATH  
NEVER OPERATE THIS UNIT UNLESS EMERGENCY STOP FUNCTIONS PROPERLY**

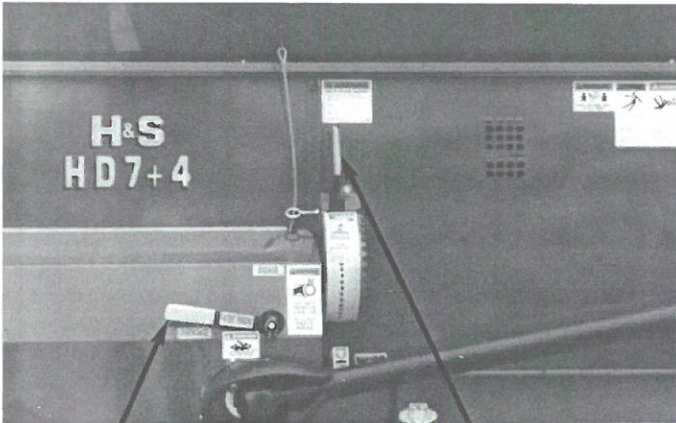

1. Pushing the emergency stop bar rearward or pulling the trip cables will activate the stop to disengage position.
2. Activating emergency stop only stops box functions. The PTO shaft will continue to rotate.
3. Keep excessive slack out of trip cables.
4. Trip emergency stop occasionally, and when starting the unit after periods of storage to insure proper function.
5. To reset, move lever (A) clockwise to engage position.

## UNLOADING - FRONT UNLOAD

**INSERT PIN UNTIL FLUSH.  
TURN CLOCKWISE UNTIL LOCKED.  
INSERT QUICK PIN TO  
LOCK IN POSITION.**

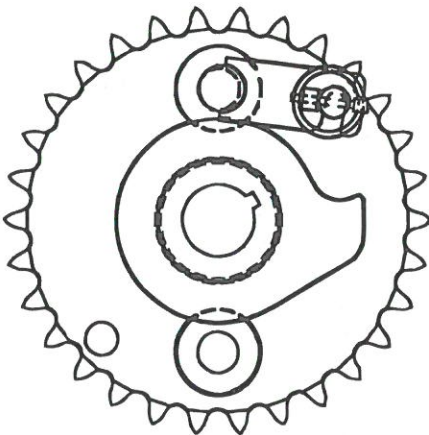

**PIN MUST BE IN END OF  
DESIRED UNLOADING ONLY.**

1. Park forage box on level ground whenever possible during unloading. Lock tractor parking brake.
2. Connect PTO to tractor, locking securely in place. USE 540 PTO ONLY.
3. Engage PTO.
4. To engage cross conveyor INTERMITTENTLY, rotate clutch lever (A) clockwise and hold with hand pressure. If hand pressure is removed, the cross conveyor will stop.
5. To engage the cross conveyor CONTINUOUSLY, rotate clutch lever (A) clockwise until it locks in the engaged position. Cross conveyor speed is controlled by tractor RPM only.

6. Quickly engaging/disengaging beaters (lever B) will allow beaters to clear material a little at a time to avoid exceeding blower capacity.
7. When beaters are clear of material, move control lever (B) to apron speed positions. Variable speed drive offers you a number of unloading speeds to choose from. With experience and depending on the type of forage, you will be able to select a speed which will match your blower capacity. Unloading speed may also be varied by increasing or decreasing engine speed of tractor.

## UNLOADING *(Continued)*

8. If it is necessary to trip the stop mechanism and disengage forage wagon drive before the wagon is empty, restart unloading by engaging clutch lever (A). (Shown on Page 10)
9. Clean out position is for cleaning out forage box at the end of load.
10. When forage box is empty, return control lever (B) to beater disengage position while PTO is still running. (Shown on Page 10)
11. Move control lever (A) to disengage position. (Shown on Page 10)
12. Disconnect PTO and place in convenient holder for field and road use.

## EMERGENCY STOP

In case of an emergency, pushing emergency stop panel or pulling the safety cable will stop cross conveyor, beaters, and main aprons. PTO will continue to rotate. Trip emergency stop occasionally to insure proper function.

- A. Emergency Stop Panel
- B. Emergency Stop Cable

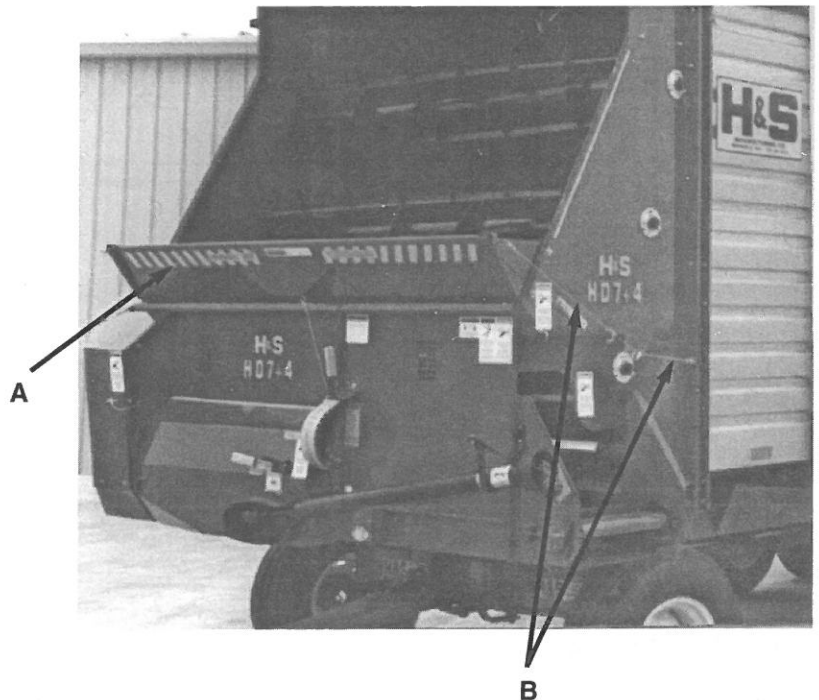

### **WARNING**

**WHEN OPERATING FORAGE BOX AS A REAR UNLOAD, OPERATOR SHOULD REMAIN IN TRACTOR SEAT AND KEEP ALL OTHERS WELL CLEAR.**

**EMERGENCY STOP DOES NOT STOP FORAGE BOX WHEN BEING OPERATED AS A REAR UNLOAD.**



**WARNING:** Some photographs used in the following pages show guards or shields removed for clarification. **NEVER** operate machine until these guards or shields are in proper operating position.

# BEFORE OPERATION

Check entire unit carefully before first operation. Tighten bolts, set screws, and chains which might have come loose in handling. Lubricate as explained in the lubrication guide. Run entire feeding mechanism and unloading mechanism for several minutes. This will serve as a break-in and as a check that all parts are assembled and lubricated properly. Successful operation will be achieved by periodic adjustments and experience of the operator. Make sure to read and understand the main feeder apron adjustments.

## Hitch To PTO Length – Tractor Drive Only

Maintain correct distance between tractor drawbar hitch and tractor PTO and tractor drawbar hitch and the universal joint at front of unit. This is necessary to prevent overextending the universal joint shaft.

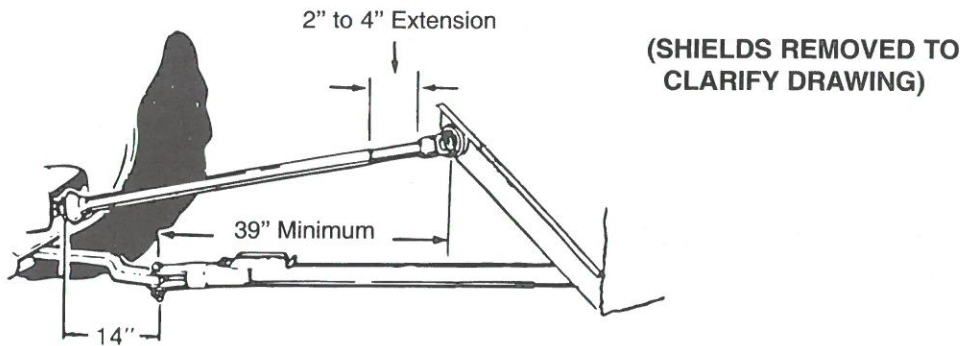

**IMPORTANT! DO NOT operate unless 2" minimum extension is maintained.**

The tractor drawbar should be adjusted in relation to the tractor PTO shaft as follows:

1. Hitch point of drawbar 14 inches behind tractor PTO shaft.
2. Hitch point of drawbar at least 8 inches, but not more than 14 inches below PTO shaft.
3. Hitch point of drawbar at least 13 inches, but not more than 22 inches above ground level.
4. When unloading, keep hitch point of drawbar - PTO shaft - in a straight line to forage box - having PTO at an angle will result in a pounding noise and damage to U joints and the safety clutch.

**! DANGER**



**ROTATING DRIVELINE  
CONTACT CAN CAUSE DEATH  
KEEP AWAY!**

**DO NOT OPERATE WITHOUT-**

- ALL DRIVELINE, TRACTOR AND EQUIPMENT SHIELDS IN PLACE.
- DRIVELINES SECURELY ATTACHED AT BOTH ENDS.
- DRIVELINE SHIELDS THAT TURN FREELY ON DRIVELINE.

1494L

The Power Take Off Shaft from tractor to box should not be connected for road travel or field operation. Damage may result to the PTO Shaft. A convenient hanger is provided to hold PTO Shaft during the time it is not being used to unload. (See item A)

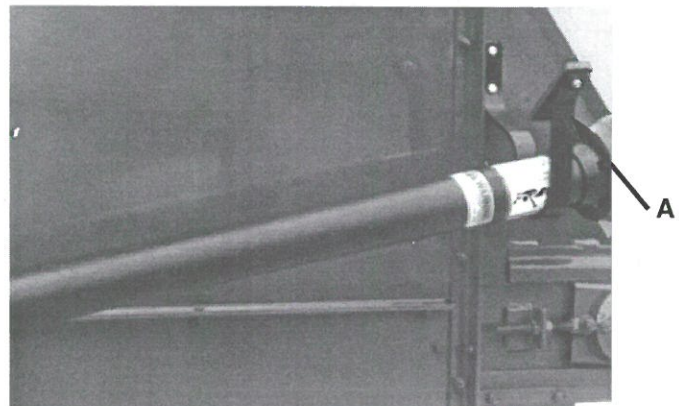



Red Reflective Tape (B)

WHEN TRANSPORTING ON THE HIGHWAY OR ROADS, PLACE SMV SIGN IN SOCKET PROVIDED AND REGULARLY CLEAN THE REFLECTIVE TAPE AT THE REAR OF THE FORAGE BOX.

**NOTE:** Obey all state and local laws, concerning towed equipment, on public roads.

For light information (See Page 25)

Mounting Socket for SMV Emblem (A)

### MAIN FEEDER APRON ADJUSTMENT

 <b>WARNING</b>

<p><b>DO NOT CLEAN OR WORK ON THIS MACHINE WITHOUT FIRST DISENGAGING POWER AND SHUTTING OFF TRACTOR ENGINE</b></p>

Four main feeder apron adjustment bolts are located at the rear of the forage box. Two are located at the center of the box and are accessible from below the frame. Left hand tightener bolt is located in panel behind drive shield at left hand corner of box. Right hand tightener and bolt is located in panel at right rear of corner of box.

All apron chains must be taken up evenly before you use the forage box. Check again after the first few loads. The Main Feeder Aprons should be at proper tension at all times. Tighten the full threaded bolts (A) to adjust aprons. Aprons are properly adjusted when two Cross Slats, or about three feet of chain lift off the Chain Return Slides from the rear of the box. When proper adjustment is reached, lock two center bolts by bending ends of locking tab against flat side of bolt head. Outside tightener bolts are locked with lock nut tightened against idler shaft. Maintain this tension when operating the box.

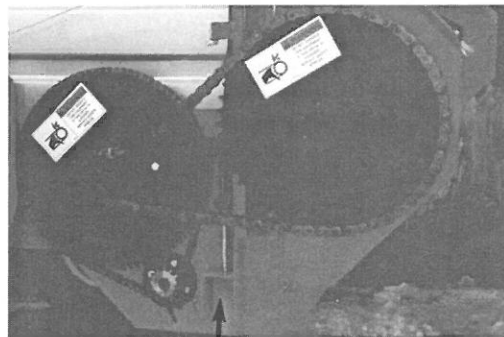

Left Side Apron Tightener Bolt

A

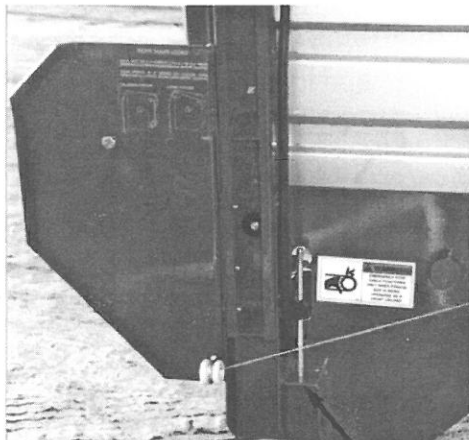

Right Side Apron Tightener Bolt

A



Center 2 Tightener Bolts

A

# CROSS CONVEYOR

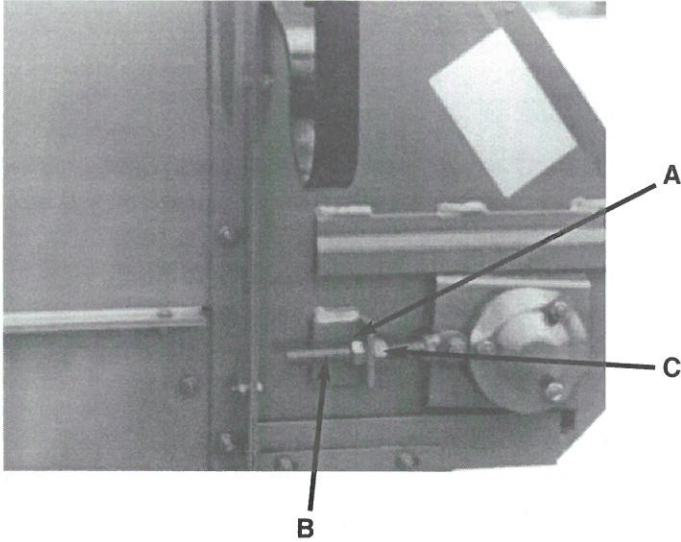

## ADJUSTMENT

Proper tension should be maintained on cross conveyor chain when operating box. To adjust cross conveyor, loosen the jam nuts (A) on tightener bolts (B). Move adjusting nuts (C) on tightener bolts until proper tension on chain is reached. The chain is properly adjusted when the center slats clear the bottom return pan by about 1/16 of an inch. Adjust both sides equally. Lock in place with jam nuts.

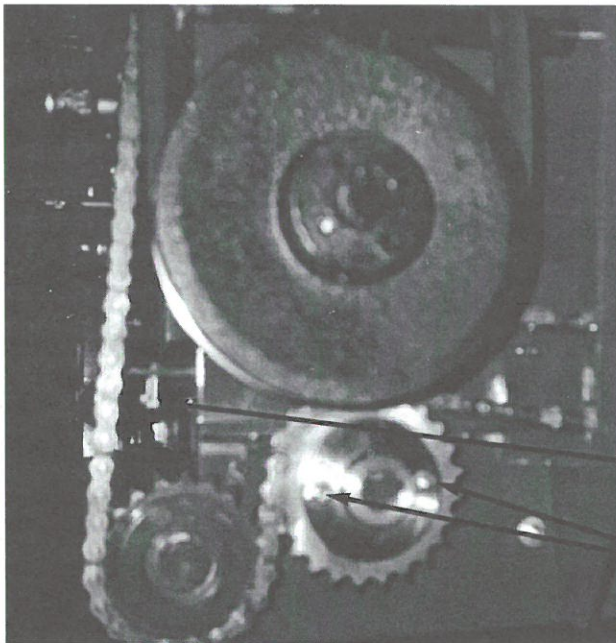

## SHEAR BOLT

The cross conveyor is protected by two shear bolts, located in the drive sprocket and shear hub assembly, located at the right hand end of cross conveyor. Two spare shear bolts are provided. Always determine the cause of failure and eliminate the cause before installing new shear bolts. Use only H&S shear bolts, part number RGB38 when replacing shear bolts.

A. Spare Shear Bolts

B. Shear Bolts



Shown here is the spring loaded plastic guard which protects the operator from accidentally being exposed to the bottom beater at the discharge opening during operation of forage box. Keep this guard in proper position at all times when operating forage box.



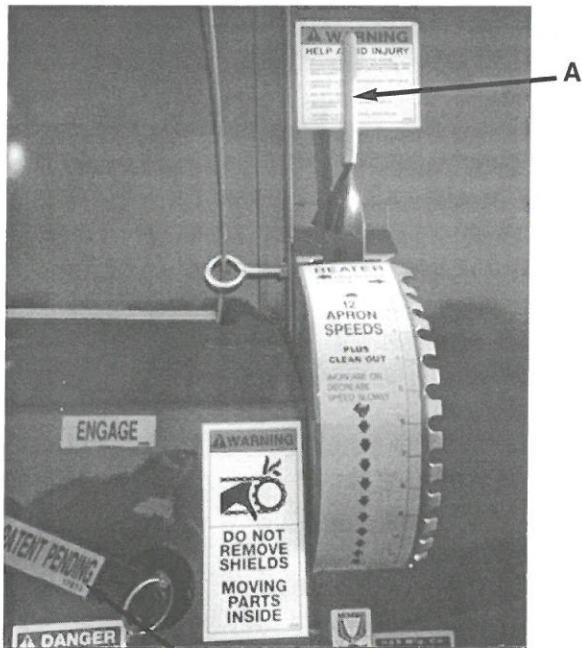

## BEATER ENGAGE, APRON SPEED CONTROL LEVER

This single lever (A) controls both beater engage/disengage and the speed of the main feeder aprons. **CAUTION: DO NOT ENGAGE BEATERS OR MAIN APRONS WHEN CROSS CONVEYOR IS FULL OF MATERIAL OR DAMAGE TO FORAGE BOX WILL RESULT.** Prior to engaging beaters and main aprons, intermittently rotate emergency stop lever (B) to the engage position to clear cross conveyor of all material. When beater control lever is engaged, the beaters and main aprons will start at the same time. **AFTER UNLOADING, ALWAYS RETURN THE CONTROL LEVER TO THE NEUTRAL POSITION WITH PTO RUNNING.**

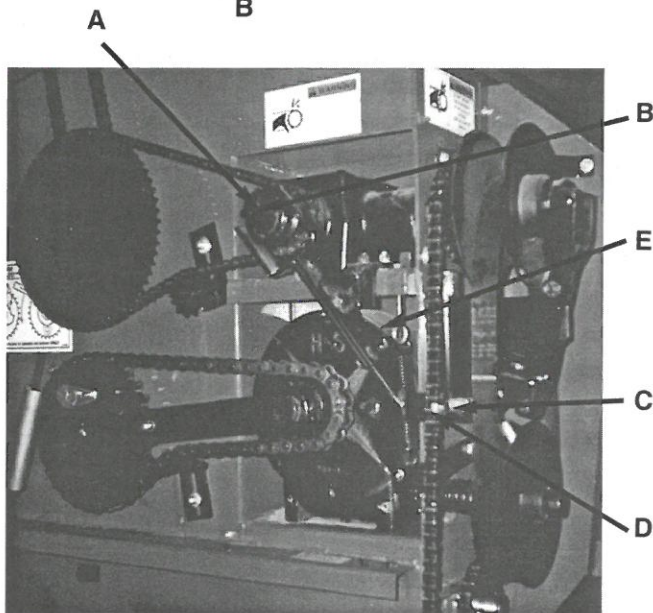

## BEATER CLUTCH ADJUSTMENT

Check beater clutch periodically to insure beaters are being completely engaged or disengaged. Beater engage/disengage clutch is properly adjusted when there is 1/8 inch of clearance between clutch jaw (A) and engaging pin (B), when control lever is in the disengage position. Basic adjustment can be made by positioning adjusting nut (C) 2-7/8" from end of control rod. Place control arm (D) tight against nut. Adjust mounting bracket (E) in slotted holes on unit until 1/8" clearance is reached. Fine adjustment is made by adjusting nut (C) on control rod.

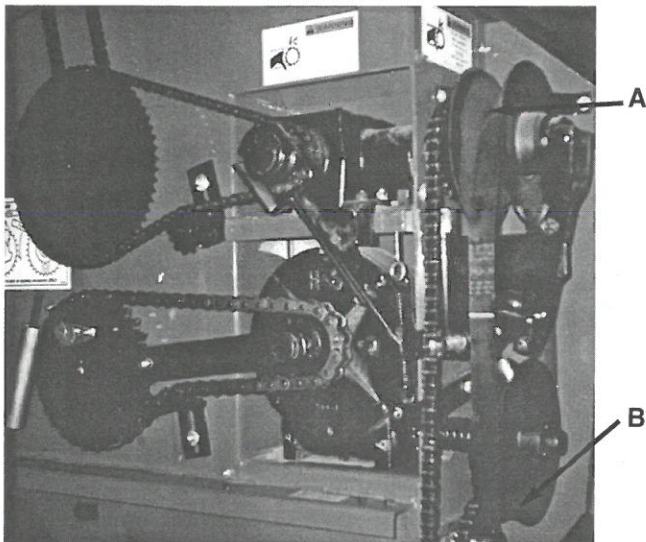

## VARIABLE SPEED DRIVE BELT

After extended use of forage box, it may become necessary to adjust or replace variable speed drive belt.

## REPLACEMENT

If it becomes necessary to replace the variable speed drive belt, follow the steps listed below to remove worn belt:

1. Place control lever in beater disengage position.
2. Open upper sheaves (A) so belt rests on drive pins.
3. Remove belt from lower sheaves (B) first and then upper sheaves.

Reverse the above steps when installing new belt.

## VARIABLE SPEED BELT ADJUSTMENT

### ADJUSTMENT

You should rarely have to adjust the variable speed drive belt. If, however, it becomes necessary to adjust the belt, follow the steps listed below:

1. Remove belt as previously instructed.
2. Move control lever to the highest apron speed position.
3. Check upper sheaves (A), if base of sheaves are not tight together, it is necessary to adjust.
4. Remove bolt from control rod (B).
5. Slide sheaves tight together, being sure control yoke (C) is tight against thrust bearing and sheaves.
6. Adjust control rod (B) so hole in control yoke and rod align, then one additional turn.
7. Replace bolt. Allow sufficient play when tightening, so control rod pivots.
8. Place control lever in beater disengage position and replace belt.

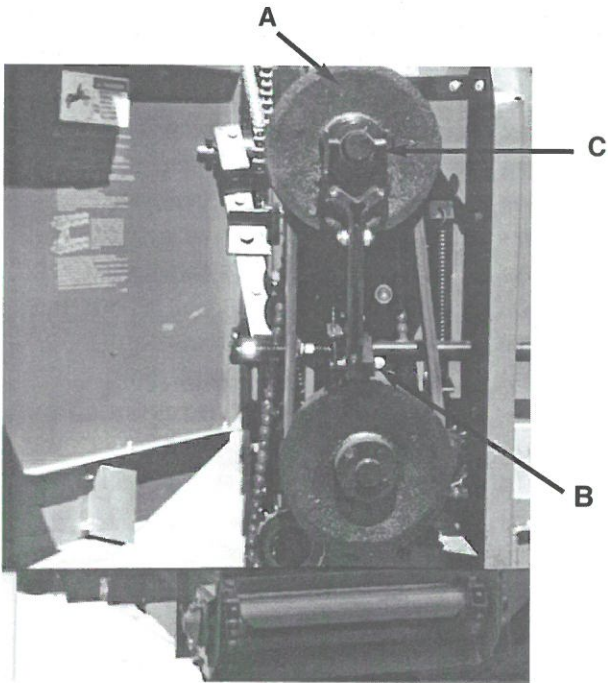

<b>⚠ WARNING</b>	
	<b>DO NOT CLEAN OR WORK ON THIS MACHINE WITHOUT FIRST DISENGAGING POWER AND SHUTTING OFF TRACTOR ENGINE.</b>

## LUBRICATION GUIDE

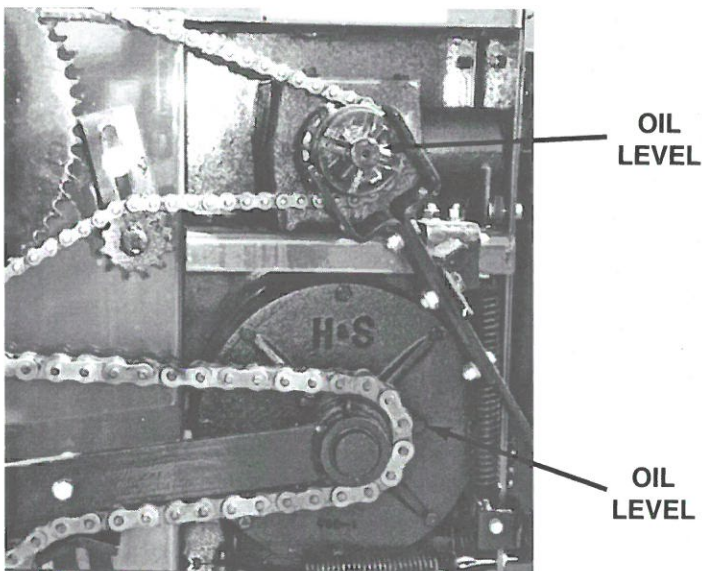

The operator should become familiar with all lubrication points and establish a systematic routine to insure complete and quick lubrication of the machine.

**GEARBOXES** – Before using your new machine, check the oil in the main apron drive and beater drive gearbox. Keep the main apron gearbox filled to the oil level plug in cover of gearbox. Beater drive gearbox should be filled to the center of the shafts. Use 80W-90 gear lube.

**DRIVE CHAINS** – Lubricate the drive chains with a light machine oil. Keep chains aligned with sprockets, this will lengthen the life of the sprockets and chain. Lubricate chains often.

## LUBRICATION GUIDE *(Continued)*

There are 34 grease fittings on your new H&S H D 7+4 two-way forage box. Grease daily during normal use and before and after storage. Use a good grade of high quality grease.

- A. (2) one at each end of PTO at U-joint
- B. (1) one on variable drive outer upper sheave
- C. (1) one on variable drive inner lower sheave
- D. (1) one on beater drive clutch
- E. (1) one on sprocket type chain tightener - beater drive chain
- F. (2) one at each end of brace - gearbox to main apron drive shaft.
- G. (1) one on cross conveyor drive shear sprocket
- H. (2) remote fittings for right hand and center main apron drive shaft bushings
- I. (6) beater bearings -one at each end of each beater (sealed bearings – DO NOT over grease)
- J. (1) one on left hand main apron drive shaft bushing
- K. (8) one on each main apron rear idler sprocket
- L. (1) one on beater engage bronze yoke
- M. (1) one on drive shaft end of brace for rear main apron drive shaft
- N. (1) one on gear reduction sprocket at rear of forage box
- O. (3) one on left, center and right hand rear drive shaft brackets
- P. (1) one on Cross Conveyor Drive Belt Tightener Bracket (Under Shield)
- Q. (1) one on Cross Conveyor Clutch Control Handle (Under Shield)

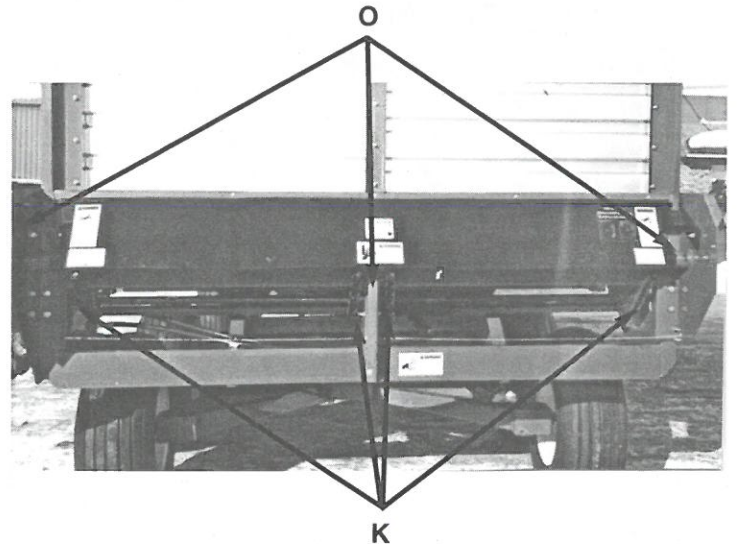
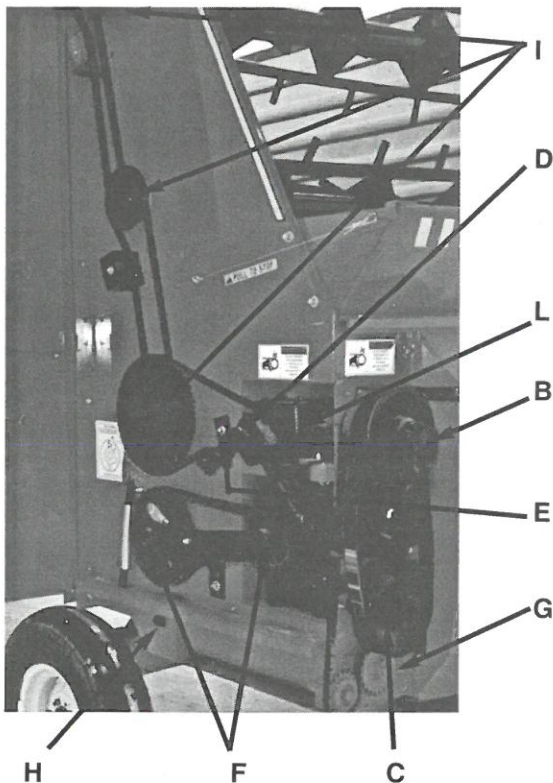
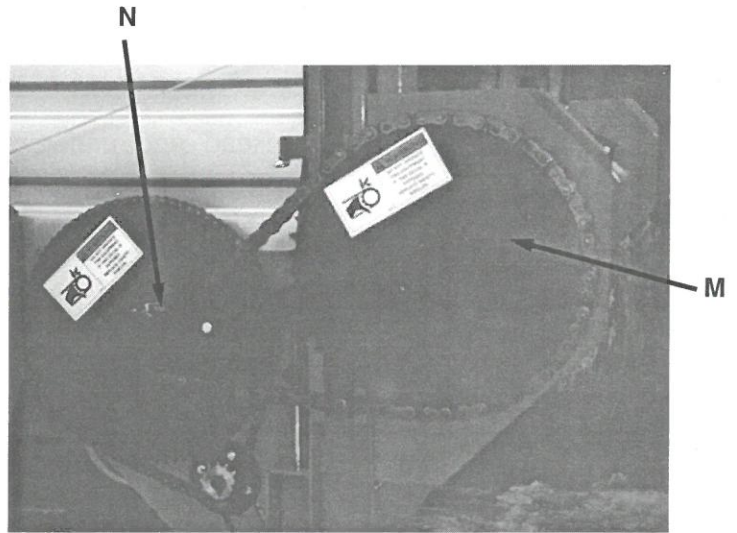
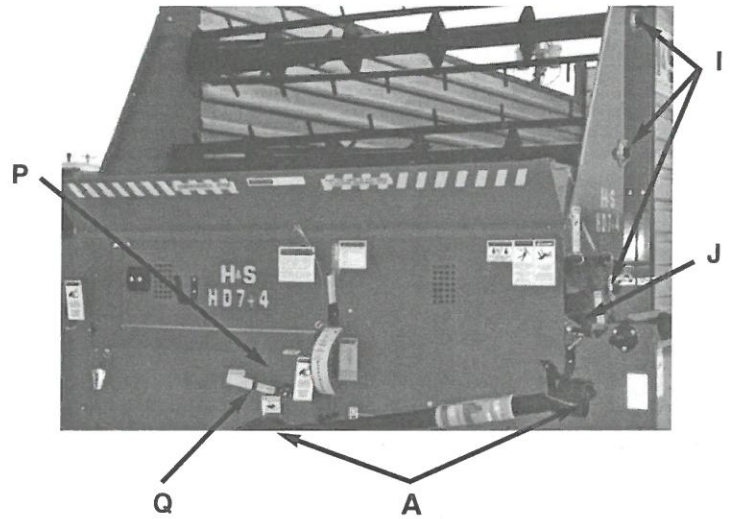

## UNLOCKED POSITION

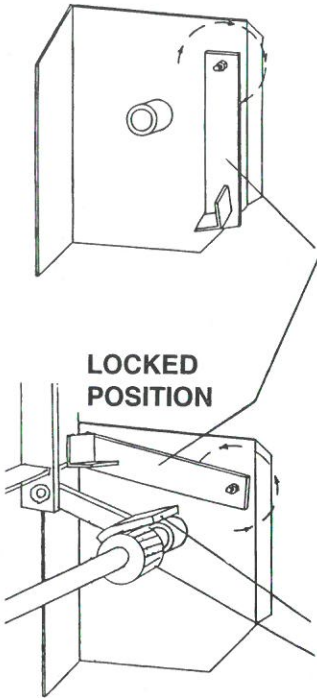

## REAR DOOR LOCKS

Located on the inside of the left and right hand rear drive shaft brackets are the rear door locks. These locks should be locked up against rear door frame when forage box is being unloaded toward the front. (LOCK BEFORE LOADING). Door locks must be unlocked (down position) when forage box is being unloaded toward the rear. (UNLOCK BEFORE LOADING).

FAILURE TO UNLOCK REAR DOOR LOCKS WHEN BOX IS BEING UNLOADED TO THE REAR WILL RESULT IN SEVERE DAMAGE TO THE FORAGE BOX.

## DOOR LOCK

## REAR DOOR LATCHES

Located at the bottom left and right hand side of the rear door are the door latches. These latches lock against knurled gears on rear drive shaft to hold door closed when operating forage box as a rear unload. When tractor hydraulics are activated and rear drive shaft turns, knurled gears flip latches open to allow rear door to swing free. Upon completion of unloading check rear door to insure that door latches are securely in place for next load.

## DOOR LATCH KNURLED GEAR

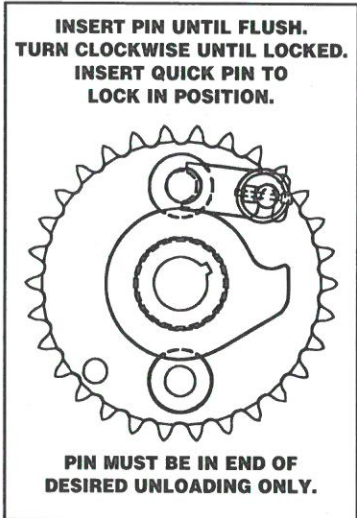

## FIELD OPERATION OF FRONT / REAR UNLOAD FORAGE BOX

Read and understand operator's manual before placing unit into operation. Check entire unit carefully before operating.

## SET-UP

To operate this forage box as a **rear unload**, the following steps must be followed:

1. Remove clip pin (PB190) holding drive pin (PB191) in front drive sprocket assembly. Rotate pin counter-clockwise and remove from assembly. Re-insert drive pin into rear drive sprocket. Rotate pin clockwise until it locks into groove on peg. Secure with clip pin.
2. Adjust rear chain tightener so there is slight deflection at the center of chain.
3. Unlock rear door locks located on the inside of the left and right hand rear drive shaft brackets. **CAUTION:** Rear door locks should be locked in position only when using front unload. While operating rear unload, rear door locks **MUST** remain unlocked. (See Above).
4. Attach hydraulic hoses to the couplers on the front unloading unit.
5. Make sure all adjustments have been made and machine is properly lubricated per operator's manual prior to operation.
6. Replace and properly secure all safety shields.
7. Prior to filling forage box, connect hydraulic hoses from forage box to the tractor. Operate rear unload to insure rear door is opening properly and drive mechanism operates properly.

**! DANGER**



**STAY CLEAR OF BEATER  
AND/OR CROSS CONVEYOR  
IF POWER SOURCE OR  
PTO IS RUNNING**

**FAILURE TO HEED THIS  
WARNING MAY RESULT IN  
PERSONAL INJURY OR DEATH**

**KEEP CLOTHING, YOURSELF  
AND OTHERS WELL CLEAR.**

# ! WARNING

**WHEN OPERATING FORAGE BOX AS A REAR UNLOAD, OPERATOR SHOULD REMAIN IN TRACTOR SEAT AND KEEP ALL OTHERS WELL CLEAR.**

**EMERGENCY STOP DOES NOT STOP FORAGE BOX WHEN BEING OPERATED AS A REAR UNLOAD.**

## BASIC OPERATION

1. Park forage box on level ground whenever possible during unloading.
2. Connect hydraulic hoses from forage box to the tractor.
3. With operator in the tractor seat and all others well clear of forage box, engage tractor hydraulics. **NOTE:** Rear unload operates in only one direction. If the tractor hydraulic system stalls, reverse the lever on the tractor or switch the hydraulic hoses at the port on the tractor.

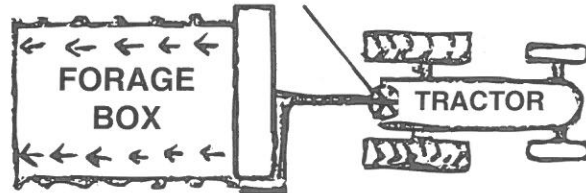

4. During unloading, move the forage box forward to allow material to fall way from rear of box.
5. When box is empty, disengage tractor hydraulics, disconnect hoses from tractor, and securely wrap hoses on convenient holder on the front unloading of unit.
6. Check rear door to make sure it is securely latched. **CAUTION:** Rear door locks must be in unlocked position (see operator's manual page 18) when set up as rear model.

## ADJUSTMENT

A roller type chain tightener is provided to adjust tension on roller chain between drive sprocket and main apron drive shaft. Chain is properly adjusted when there is slight deflection at the center of the chain.

## TIGHTENER

The roller chain between hydraulic motor and large reduction sprocket is adjusted by loosening the four bolts holding motor. Slide motor downward in slots in panel until chain is tight. Retighten four bolts holding motor.

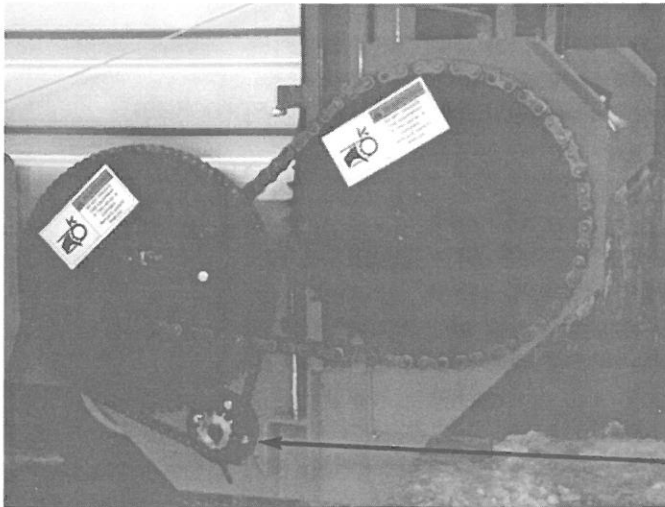

**MOTOR MOUNTING BOLTS**

# ENTERING FORAGE BOX FOR CLEAN OUT OR REPAIR

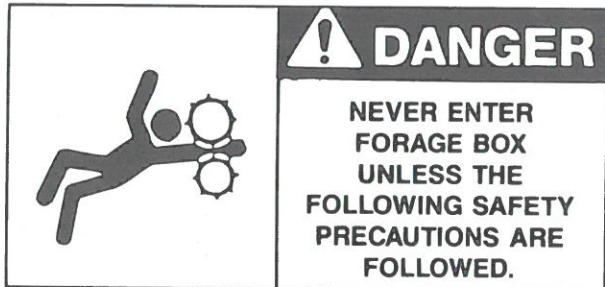

When forage box is empty, entry can be made through rear door. Use the following steps when entering forage box through rear door.

1. Shut off tractor.
2. Disconnect PTO and/or hydraulics from tractor and place in appropriate hanger.
3. Securely block rear door open to prevent accidental closure or entrapment.
4. Use a small ladder or similar climbing device to enter the rear of forage box.

When forage box is not empty use the following procedures:

Use the following steps when entering forage box when NOT planning to run cross conveyor.

1. Shut off tractor.
2. Disconnect PTO from tractor and place in PTO hanger.  
Disengage tractor hydraulics and disconnect quick couplers at tractor.
3. Place control lever in beater engage position. This will prevent beaters from turning while climbing over them.
4. **USE EXTREME CAUTION WHEN CLIMBING OVER BEATERS AS TINES ON BEATERS MAY CAUSE SEVERE INJURY.**



**If you plan to manually unload forage box utilizing cross conveyor, the following two-man procedure must be followed. NEVER ATTEMPT THIS PROCEDURE ALONE. PERSON OUTSIDE OF FORAGE BOX OPERATING CONTROLS MUST NOT LEAVE CONTROLS.**

1. Place control lever in beater disengage position.
2. Disengage tractor PTO and shut off tractor.  
Disengage tractor hydraulics and shut off tractor.
3. Remove variable speed drive belt. This will prevent main aprons from moving.
4. Remove connector link from beater drive roller chain and remove chain from sprockets.  
**CAUTION: BEATERS ARE NOW FREE TO ROTATE.**
5. Using a short piece of chain with hooks, secure top beater to center beater as illustrated below.

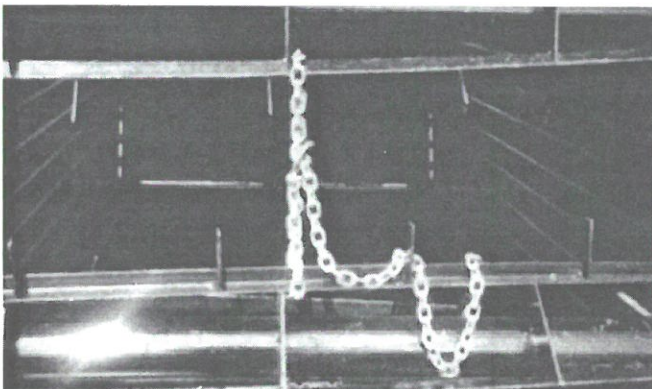

Wrap chain around bottom bar of third beater and top bar of second beater. Secure chain together as tight as possible to eliminate beaters from rotating in either direction. Keep excess chain out of cross conveyor chamber. **NOTE:** Hook chain properly and securely to prevent unhooking during this procedure.

6. Using extreme caution, first person may now climb over beaters.
7. When first person is clear of beaters, second person may start tractor and engage PTO to operate cross conveyor.
8. Before first person attempts to leave forage box, second person must disengage tractor PTO and shut off tractor.
9. When forage box is clear of people, remove safety chain from beaters, reinstall drive belt and beater drive chain. Adjust tightener on roller chain.

# PTO ASSEMBLY

<b>! DANGER</b>	
	<p><b>ROTATING DRIVELINE CONTACT CAN CAUSE DEATH KEEP AWAY!</b></p> <p><b>DO NOT OPERATE WITHOUT—</b></p> <ul style="list-style-type: none"><li>• ALL DRIVELINE, TRACTOR AND EQUIPMENT SHIELDS IN PLACE.</li><li>• DRIVELINES SECURELY ATTACHED AT BOTH ENDS.</li><li>• DRIVELINE SHIELDS THAT TURN FREELY ON DRIVELINE.</li></ul>

Care must be taken to keep male and female driving elements well lubricated and free sliding. The shield surfaces must be kept dry, as dirt accumulation on them will quickly cause these units to bind and not rotate. If, at any time the shields do not turn freely, they should be checked to determine the cause, and repaired or cleaned. **DO NOT STEP OVER PTO SHAFT. STAY CLEAR OF ROTATING PTO AT ALL TIMES.**

## OPTIONAL EQUIPMENT

### 12" FOLD DOWN EXTENSION

Extension folds down for easy access to blower and folds up for road and field travel.

### HYDRAULIC DRIVE

Hydraulic drive unit easily mounts and dismounts from unit (See Page 48)

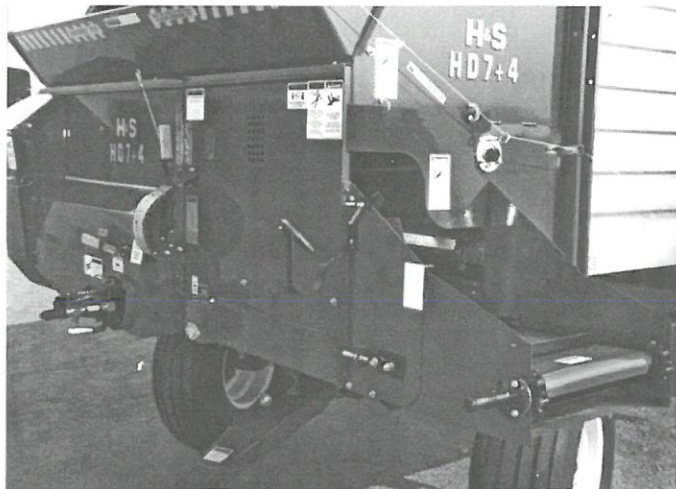

**FOLDED DOWN**



**FOLDED UP**

## DECAL LOCATION

Your H&S H D 7+4 Two-Way Unloading Forage Box was manufactured with operator safety in mind. Located on the forage box are various decals to aid in operation, and warn of danger or caution areas. Pay close attention to all the decals on your forage box.



**DO NOT REMOVE ANY OF THESE DECALS. IF DECALS ARE LOST, DAMAGED, OR IF FORAGE BOX IS REPAINTED, REPLACE DECALS. REMEMBER: DECALS ARE FOR YOUR PROTECTION AND SAFETY.**

Listed below are the decals on your H D 7+4 Two-Way Unloading Forage Box. These decals may be ordered individually by part number or by ordering a complete set.

ITEM	PART NO.	DESCRIPTION
A	1494A	(5) Warning - Do Not Operate
AA	22493H	(2) Door Locks
B	1494K	(3) Warning - Do Not Remove Shields
BB	1494O	(3) Warning - Emergency Stop Function
C	1494Q	Warning - Operator Position
CC	1494I	(2) Danger - Keep Out
D	1494B	Warning - Do Not Remove Shields
DD	1787-I	Patent Pending
E	5896B	Danger - Rotating Driveline
EE		FEMA
F		Serial Number
FF	1494F	Danger - Never Enter
G	1-1-91	Beater Engage/Disengage
GG	2495	Warning - Keep Children Away
H	7+4-2191	Clean Out
HH	11599	Warning - Stay Clear of Hydraulic Lines
I	1494P	Danger - Stay Clear of Power Lines
II	1494J	Warning - Do Not Hand Clean
J	Weasler	Danger - PTO (H&S Decal 1494L)
JJ		(3) H&S HD7+4
K		Amber Reflector
KK	5896E	Engage
L	1494H	(3) Danger - Stay Clear
LL	5896D	Disengage
M	5896A	Warning - Help Avoid Injury
O	104-3185	Push This Panel
P	5896C	Warning-To Prevent Serious Injury
Q	103-3185	Emergency Stop
R	120-2177	(2) Pull to Stop
S		(2) H&S Metal Sign (12"x24")
T		Red Reflector
U	1494C	(3) Warning - Moving Parts Under (5 on 18" Box)
V	7+4-3185G	Entering Forage Box
X	112-11176	Shear Bolt
Y	22493A	Field Operation-Rear Unload
Z	31300	Drive Pin Instructions
	7+412699FR	Complete Set of Decals
Paint - H&S Red	ZX21	Gallon
	ZX22	Quart
	ZX23	Pint



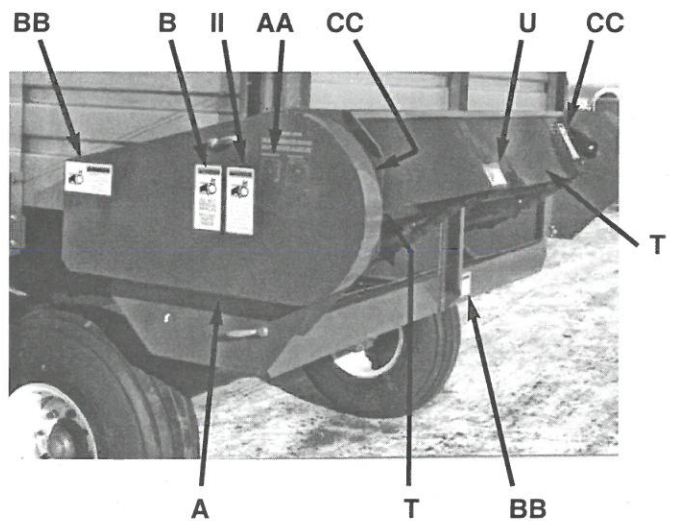
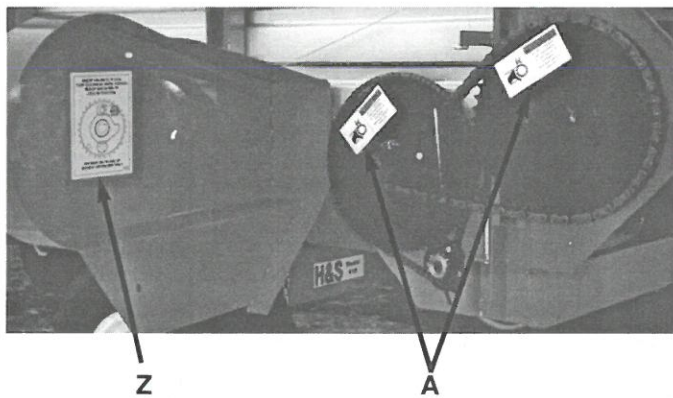
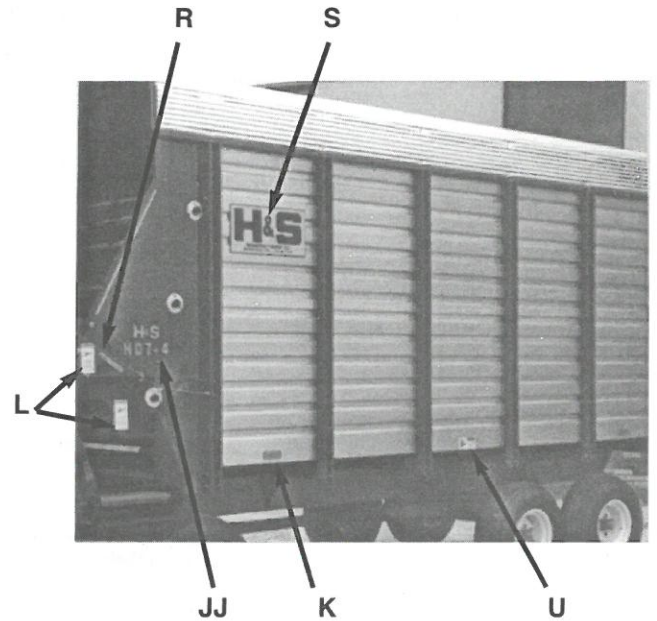
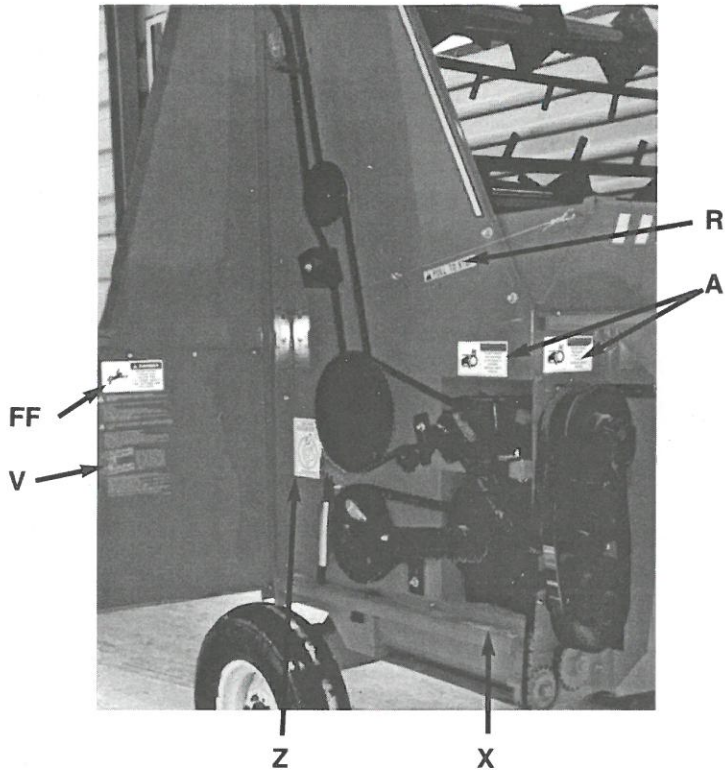
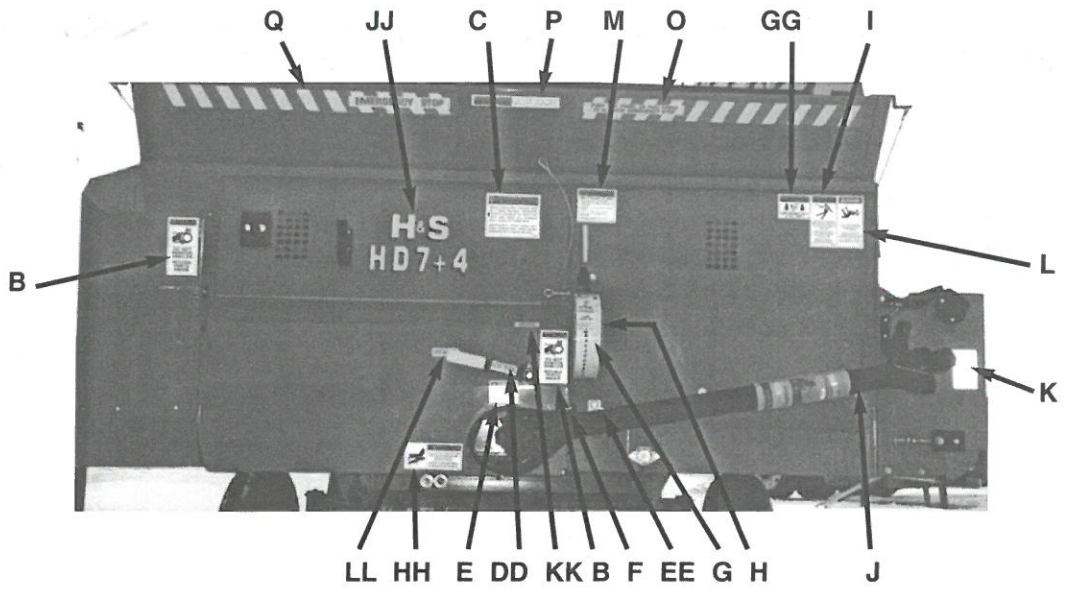

(Behind Shield)

# INSTRUCTIONS FOR ORDERING PARTS

All service parts should be ordered through your authorized H&S dealer. He will be able to give you faster service if you will provide him with the following.

1. Model & Serial Number - Both can be located on the front main panel - below control lever.
2. All reference to left or right apply to the machine as viewed from the rear.
3. Parts should not be ordered from illustration only. Please order by complete part number.
4. If your dealer has to order parts - give shipping instructions.

VIA truck - large pieces (please specify local truck lines)

VIA United Parcel Service (include full address)

<b>H&amp;S Mfg. Co.</b>	
MARSHFIELD, WIS.	
MOD. NO.	<input type="text"/>
SER. NO.	<input type="text"/>

PLEASE RECORD NUMBERS FOR YOUR UNIT FOR QUICK REFERENCE

## ABOUT IMPROVEMENTS

H&S IS CONTINUALLY STRIVING TO IMPROVE ITS' PRODUCTS.

We must therefore, reserve the right to make improvements or changes whenever it becomes practical to do so, without incurring any obligation to make changes or additions to the equipment previously sold.

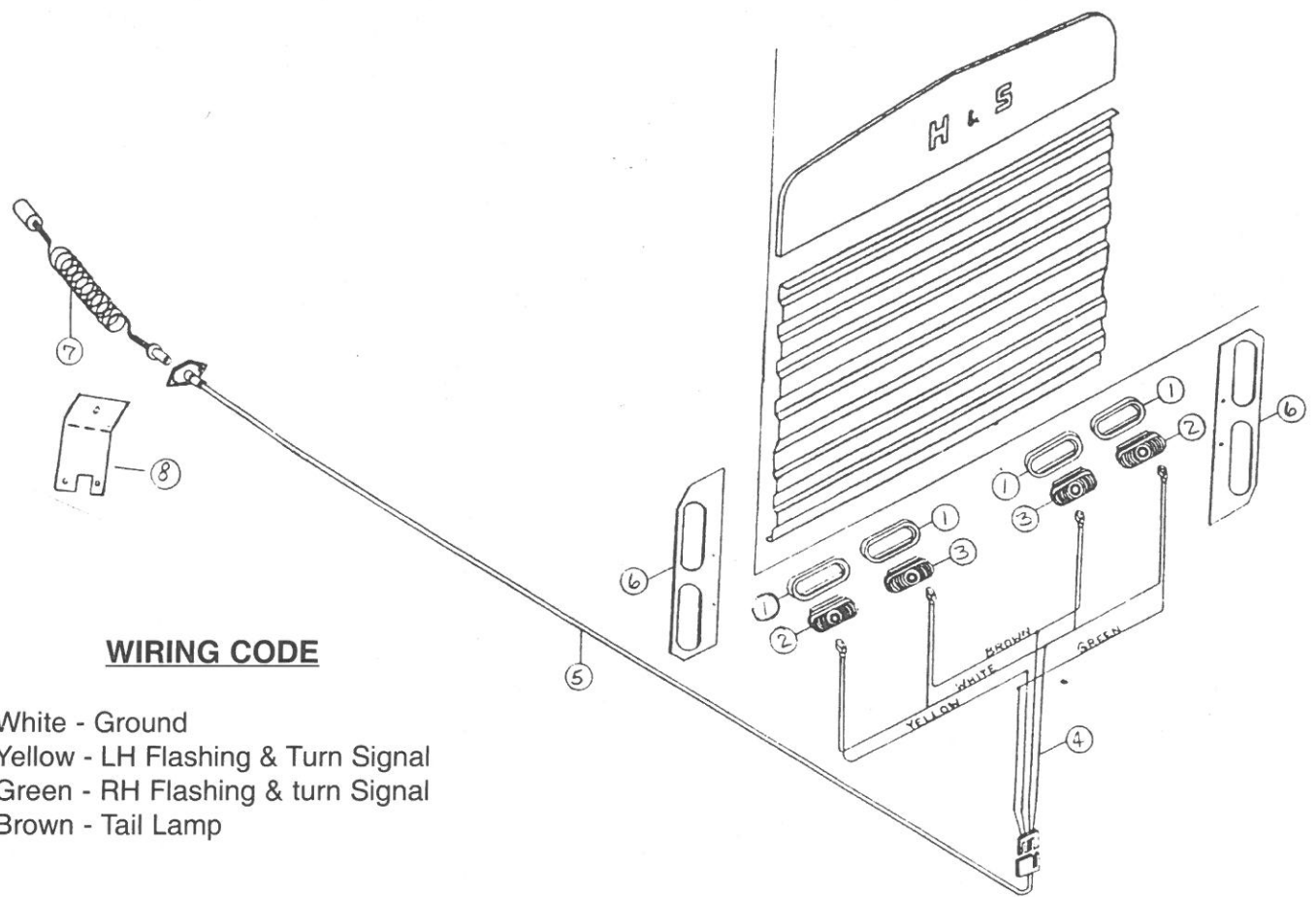

**WIRING CODE**

- White - Ground
- Yellow - LH Flashing & Turn Signal
- Green - RH Flashing & turn Signal
- Brown - Tail Lamp

**FIGURE 1  
H D 7+4 FRONT & REAR  
SELF-UNLOADING FORAGE BOX  
LIGHT ASSEMBLY**

ITEM	PART NO.	DESCRIPTION
1.	S308	Rubber Light Mount
2.	S309	Amber Light
3.	S310	Red Light
4.	S311	Light Harness
5.	PB109	18' Longitudinal Cord
	PB110	20' Longitudinal Cord
6.	PB111	Tail Light Brackets
7.	S317	Optional Tractor Cord
*	PB112	18' Complete Light Assembly Less Optional Tractor Cord
*	PB113	20' Complete Light Assembly Less Optional Tractor Cord
8.	S346	Mounting Bracket

**NOTE:** \* (Means Not Shown)

FIGURE 2

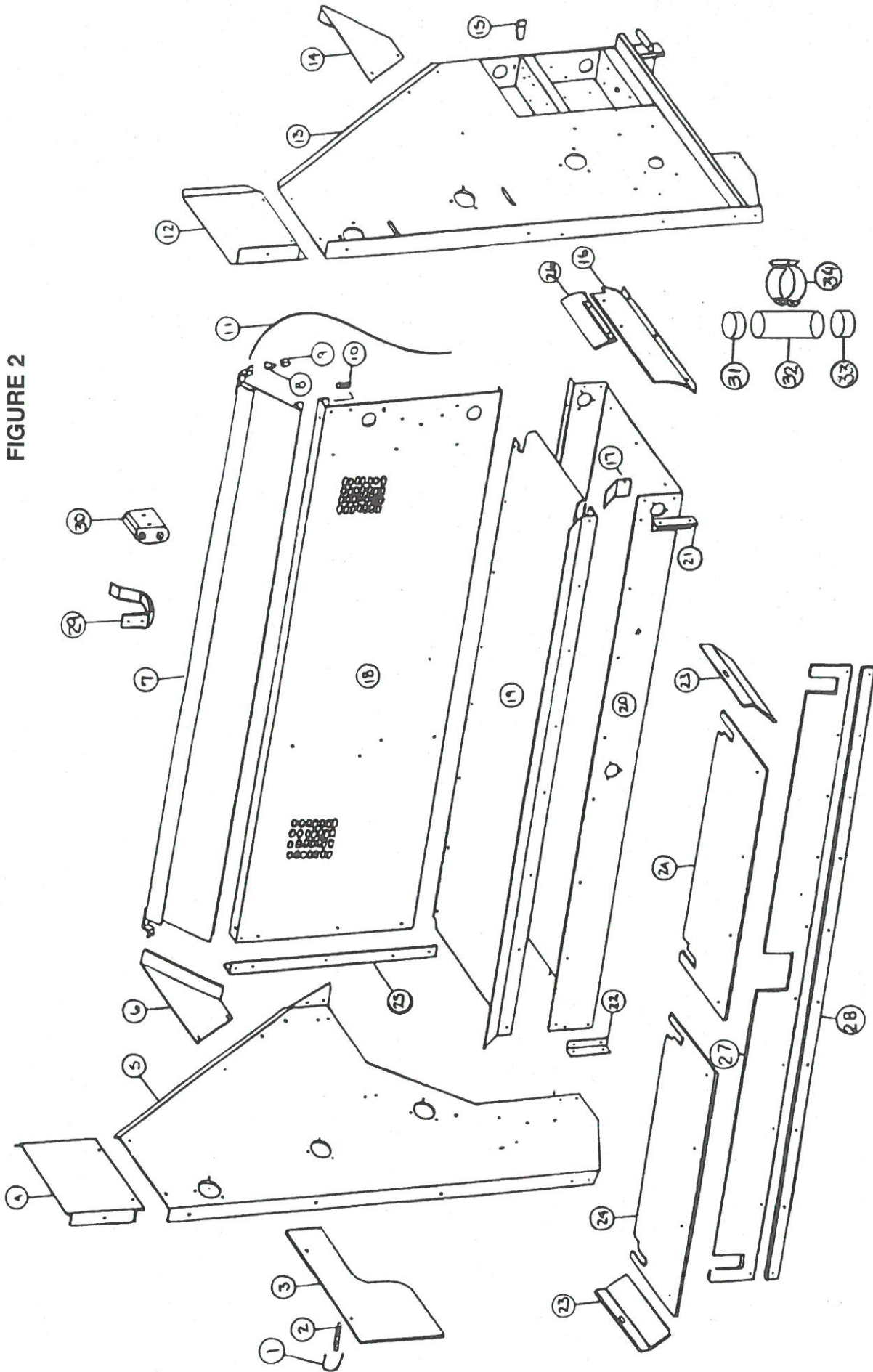

**FIGURE 2  
HOUSING COMPONENTS FOR UNIT**

<b>ITEM</b>	<b>PART NO.</b>	<b>DESCRIPTION</b>
1.	F32	U-Bolt (2)
2.	S1	Spring for Shield (2)
3.	S2	Plastic Beater Guard
4.	S3	LH Side Panel Top
5.	S4	LH Side Panel
6.	S5	LH Emergency Stop Panel
7.	S370	Emergency Stop Panel
8.	ES14	Thimble (2)
9.	ES15	Cable Clamp (2)
10.	S7	Spring for Emergency Stop (3)
11.	S8	Emergency Stop Cable
12.	S9	RH Side Panel Top
13.	S10	RH Side Panel
14.	S11	RH Emergency Stop Panel
15.	S12	Gearbox Brace
16.	S13	Return Pan End
17.	S14	Cross Apron Pan End
18.	S353	Front Main Panel
19.	S16	Cross Apron Pan
20.	S356	Return Pan
21.	S18	RH Return Pan Angle
22.	S19	LH Return Pan Angle
23.	S20	Apron Side Spacer
24.	PB74	Drive Shaft Panel
25.	S22	LH Front Angle
26.	S217	Return Pan End
27.	S420	Rubber Seal
28.	S288	Rubber Seal Strap
29.	PB79	Hydraulic Hose Holder
30.	JB105	Hose Coupling Holder
31.	S414	Cap
32.	S415	Manual Holder Tube
33.	S418	Cap W/Hole
34.	S416	Manual Hanger Clamp

FIGURE 3

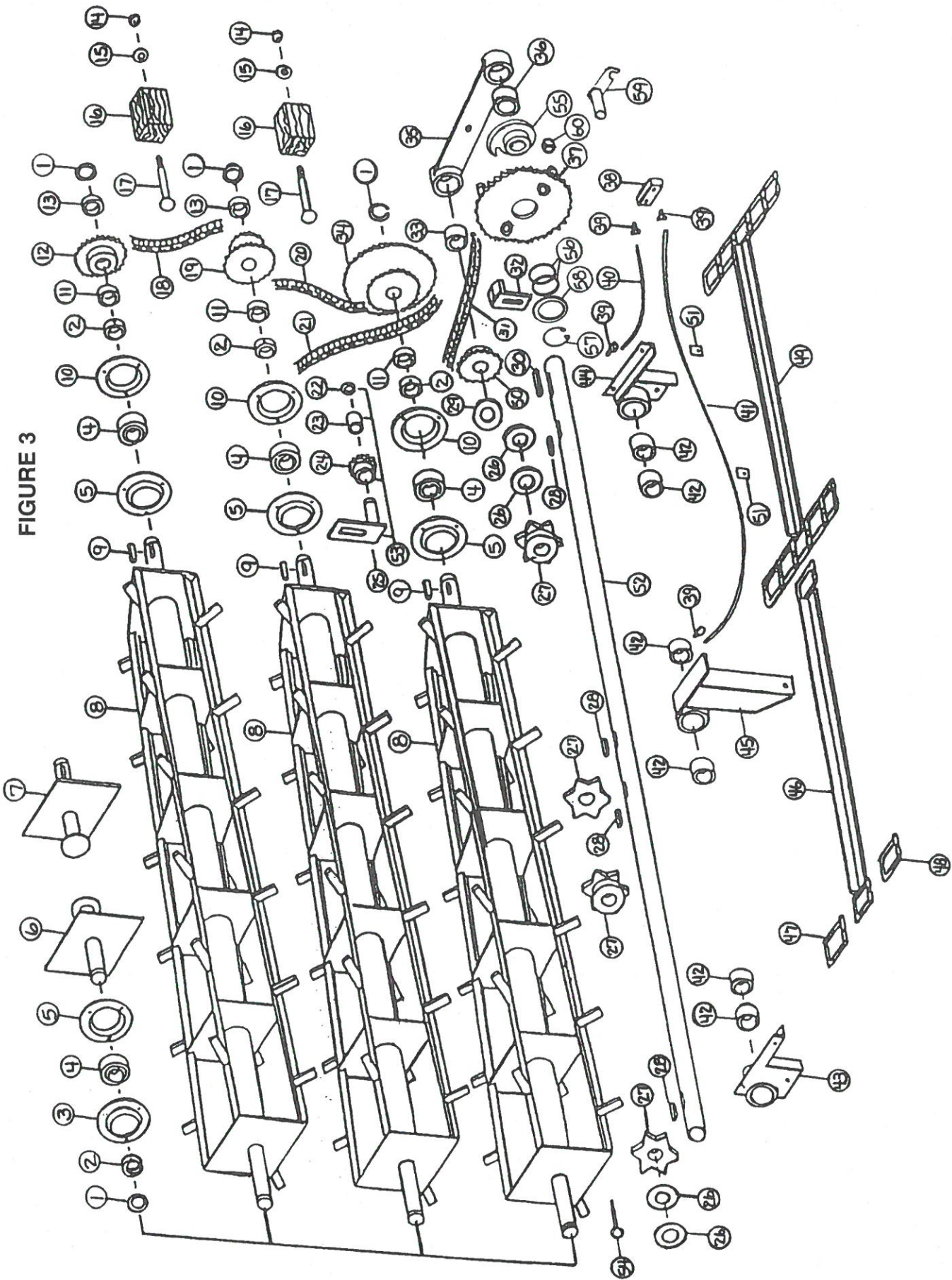
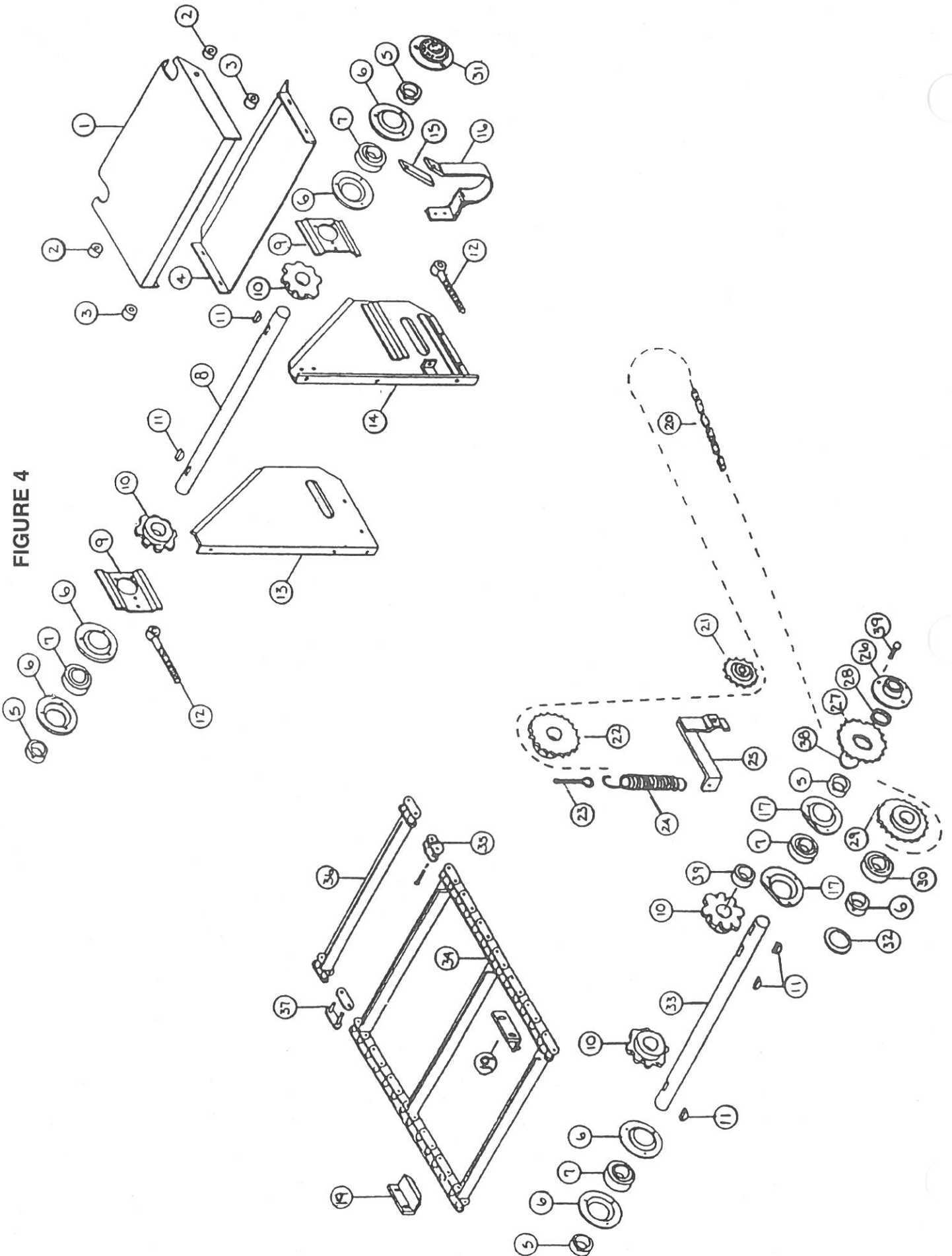

**FIGURE 3**  
**BEATERS AND MAIN APRON DRIVE**

ITEM	PART NO.	DESCRIPTION
1.	F73	Snap Ring
2.	F16	Lock Collar
3.	F114	Bearing Flange w/Zerk
4.	F115	Bearing Greaseable Type
5.	F14	Bearing Flange
6.	S23	LH Beater Stub Shaft
7.	S24	RH Beater Stub Shaft
8.	S25	Beater
9.	G23	5/16" x 1-3/8" Square Key
10.	F114A	Bearing Flange w/Zerk 45 Degree
11.	S218	3/8" Spacer
12.	S26	3rd Beater Sprocket 20T
13.	S219	1/4" Spacer
14.	K60	Nut
15.	X67	Washer
16.	S27	Wood Chain Tightener
17.	S28	Carriage Bolt
18.	X58	2nd to 3rd Beater Chain 89 Pitches #50
19.	S30	2nd Beater Sprocket 30T - 13T
20.	S31	1st to 2nd Beater Chain 98 Pitches #50
21.	X58	Beater Drive Chain 89 Pitches #50
22.	10R32	Snap Ring
23.	S33	Chain Tightener Bushing
24.	S34	Tightener Sprocket w/Bushing
25.	S35	Chain Tightener Bracket
26.	S36	Drive Shaft Spacer
27.	S37	Apron Drive Shaft Sprocket
28.	A32	3/8" x 1-3/8" Square Key
29.	S327	Poly Gearbox Washer
30.	S38	3/8" x 2-3/8" Square Key
31.	ST10	Apron Drive Chain 56 Pitches #80
32.	S40	Chain Tightener
33.	S41	Bushing
34.	S42	1st Beater Sprocket 60T-20T
35.	S43	Drive Shaft Brace
36.	S44	Bushing
37.	PB192	Apron Drive Sprocket 30T
38.	S46	Grease Line Bracket
39.	S47	Grease Line Fitting
40.	S48	Short Grease Line
41.	S49	Long Grease Line
42.	S50	Drive Shaft Bushing
43.	S51	LH Drive Shaft Bracket
44.	S52	RH Drive Shaft Bracket
45.	S53	Center Bearing Bracket
46.	S233	667H Pintle Slat with Attachment Links
47.	11S51	667H Pintle Connector Link
48.	11S50	667H Pintle Attachment Link RH or LH
49.	S324	667H Complete Pintle Apron 16'
*	S325	667H Complete Pintle Apron 18'
*	S326	667H Complete Pintle Apron 20'
50.	ST11	Worm Gear Shaft Sprocket 13T
*	S66	Slow Down Sprocket 11T
51.	S67	Grease Line Clip
52.	S68	Main Apron Drive Chain
53.	S216	Chain Tightener Assembly
54.	BFR319	"I"-Bolt 3/8" x 2-1/2"
55.	PB117	Front Clutch Dog
56.	23N225	Bushing
57.	23N227	Snap Ring
58.	PB126	Clutch Sprocket Washer
59.	PB191	Clutch Dog
60.	PB190	Lynch Pin

**NOTE:** \* (Means Not Shown)

FIGURE 4



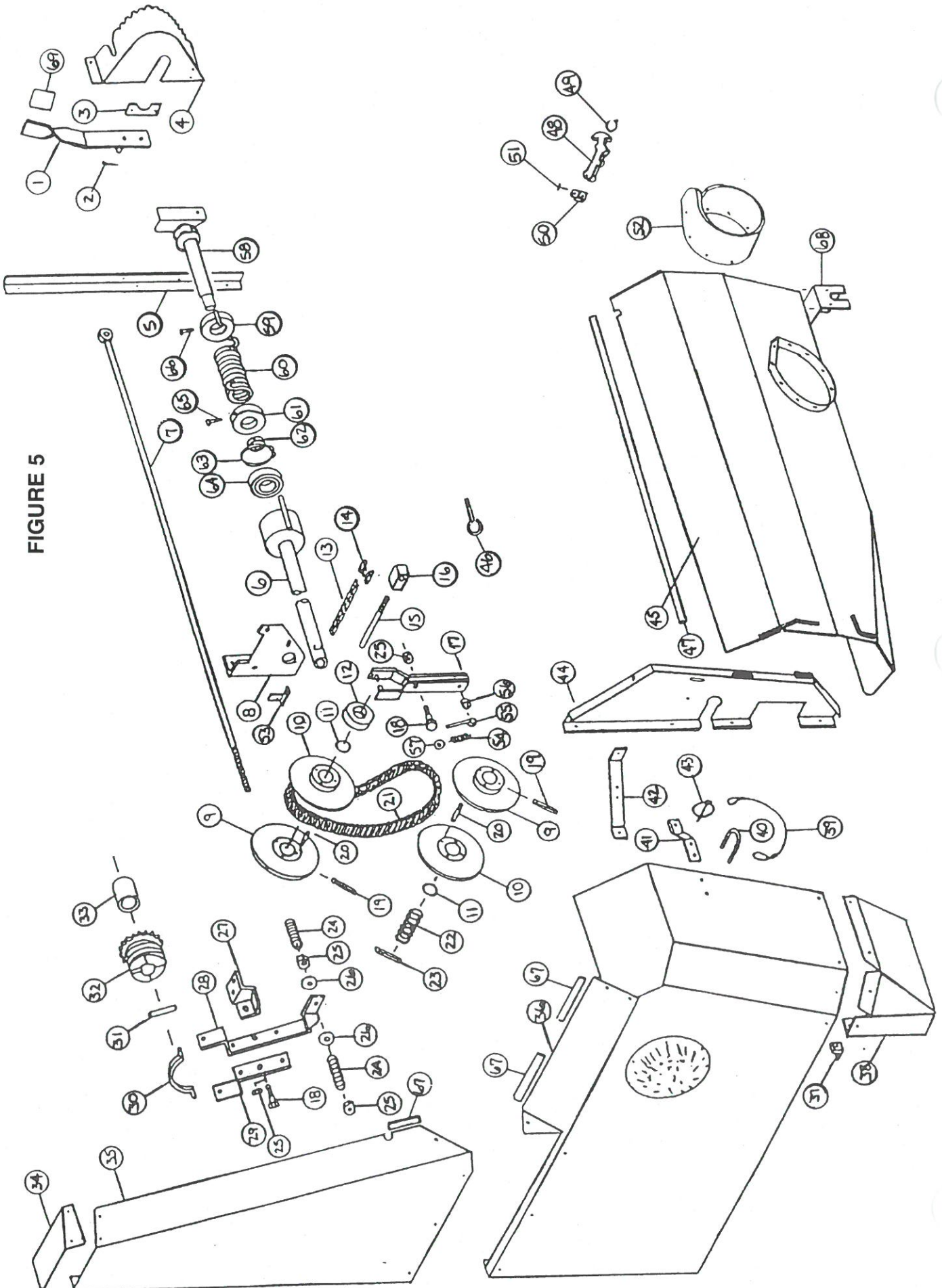

**FIGURE 4**  
**CROSS APRON AND DRIVE ASSEMBLY**

ITEM	PART NO.	DESCRIPTION
1.	S69	Cross Apron Pan Extension
2.	S70	Spacer
3.	S71	Pan Extension Carrier
4.	S72	Return Pan Extension
5.	4C9	Lock Collar
6.	4C7	Bearing Flange
7.	4C8	Bearing
8.	S73	Cross Apron Idler Shaft
9.	S74	Tightener Bracket
10.	L10R24	8 Tooth Sprocket
11.	5B10	1/4" x 1" Woodruff Key
12.	S75	Tightener Bolt
13.	S76	Tightener Panel Rear
14.	S77	Tightener Panel Front
15.	S78	PTO Holder Rubber Tab
16.	S354	PTO Holder
17.	X85	Bearing Flange Sheared
18.	K132	3/8" Spacer
19.	S223	Cross Conveyor Hold down
20.	S357	Front Drive Chain 193 Pitch #50
21.	K101	Tightener Sprocket 17T
22.	S82	Sprocket 24T
23.	ES10	5/16" x 3" I-Bolt
24.	ST36	Spring
25.	S83	Tightener Bracket
26.	S391	Shear Hub
27.	S392	Sprocket 24T
28.	S393	Bronze
29.	K89	Idler Sprocket 20T
30.	K90	Bearing
31.	S87	Cross Apron Shaft Guard
32.	K92	Snap Ring
33.	S390	Cross Apron Drive Shaft
34.	S89	Cross Conveyor
35.	K122	550 Offset Link Cross Conveyor
36.	K120	550 Slat with Attachment Links
37.	K121	550 Connector Link Cross Conveyor
38.	S394	Snap Ring
39.	RGB38	Shear Bolt 5/16" x 1" GR.2
*	X60	#50 Offset Link
*	X61	#50 Connector Link

**NOTE:** \* (Means Not Shown)

FIGURE 5

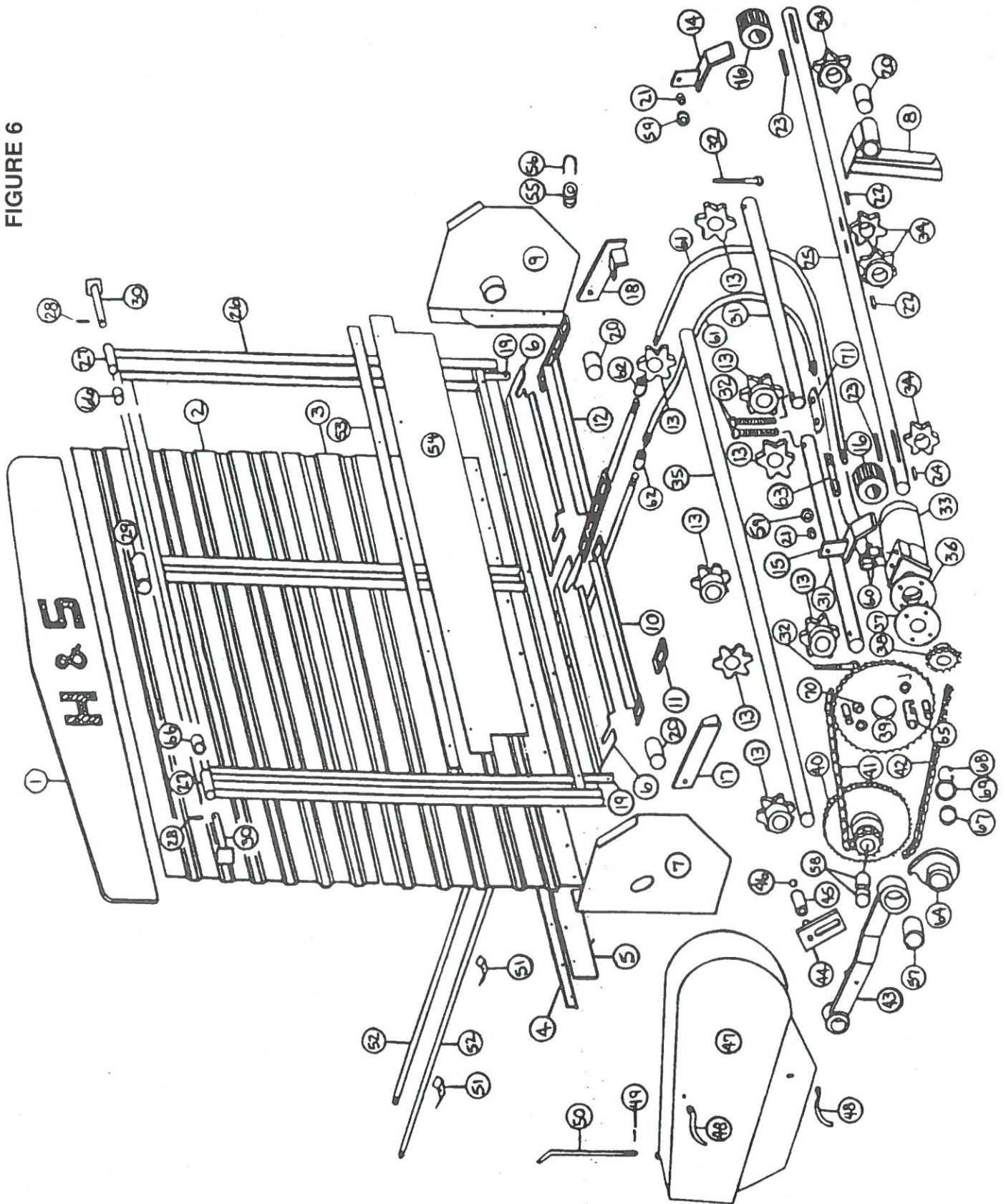

**FIGURE 5  
SHIELDS - BEATER CLUTCH - BELT DRIVE**

ITEM	PART NO.	DESCRIPTION	ITEM	PART NO.	DESCRIPTION
1.	S364	Shifter Handle	36.	S120	Main Side Shield
2.	X43	Cotter Pin	37.	D58	Shield Angle
3.	S91	Shifting Pipe Bracket	38.	S121	Side Shield Bottom
4.	S360	Speed Selector Panel	39.	S122	Clip Pin Cable
5.	S365	Front Center Angle	40.	F32	U-Bolt
6.	S366	Shifting Pipe (Apron)	41.	S123	Shield Latch Bracket
7.	S367	Shifting Rod (Beater)	42.	S234	Shield Brace
8.	S96	Shifting Bracket	43.	F56	Clip Pin
9.	S97	Stationary Sheave	44.	S333	Front Upright Shield
10.	S295	Sliding Sheave	45.	S334	Front Shield
11.	S99	O-Ring	46.	BFR319	I-Bolt
12.	S100	Thrust Bearing	47.	S359	Edging 38"
13.	S101	#40 Chain 5 Pitch	48.	X192	Front Shield Latch (Rubber)
14.	S102	#40 Connector Link	49.	X193	Latch Catch Bracket
15.	S103	Linkage Rod	50.	X194	Latch Mounting Bracket
16.	S104	Adjustment Block	51.	X195	Pin
17.	S105	Variable Speed Shifter	52.	S131	PTO Rubber Shield
18.	R10	1/2" x 1-1/4" Bolt GR.5	53.	S221	Spring Shift Bracket
19.	S106	5/16" x 2-3/4" Expansion Pin	54.	S222	Shifting Spring
20.	S296	Sheave Pin	55.	S220	Shifting Spring Rod
21.	S108	Variable Speed Belt	56.	K94	Spacer
22.	S109	Spring	57.	T16	1/4" Flat Washer
23.	S110	1/4" x 2" Expansion Pin	58.	S290	Shifter Handle Pipe End
24.	S111	Spring	59.	S291	Spring Pin Collar
25.	9S17	1/2" Lock Nut	60.	S292	Spring
26.	S285	Beater Clutch Washer	61.	S293	Spring Collar
27.	S112	Beater Clutch Bracket	62.	4C9	Lock Collar
28.	S113	Beater Clutch Long Arm	63.	K92	Snap Ring
29.	S114	Beater Clutch Short Arm	64.	K90	Bearing
30.	ST58	Clutch Yoke	65.	17G141	Bolt 3/8" x 1-1/4" GR.5
31.	S115	Beater Clutch Pin	66.	X111	Bolt 3/8" x 1" GR.5
32.	S116	Beater Clutch Sprocket	67.	S328	Edging 3-1/2"
33.	S117	Beater Clutch Bushing	68.	S346	Mounting Bracket
34.	S118	Beater Shield Top	69.	S403	Handle Grip
35.	S119	Beater Side Shield	*	S368	Complete Shifter

**NOTE:** \* (Means Not Shown)

FIGURE 6

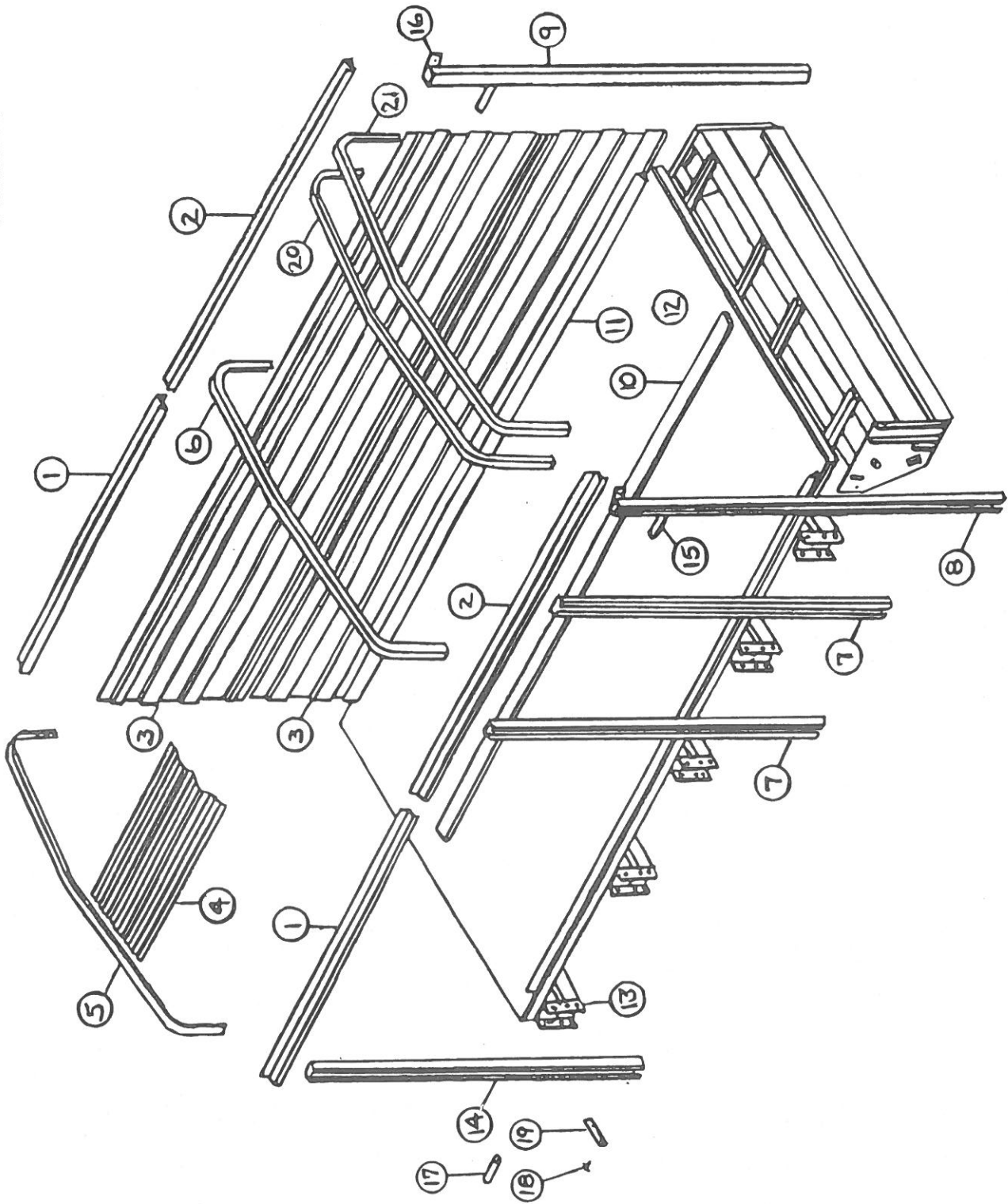

**FIGURE 6  
REAR UNLOAD ASSEMBLY**

ITEM	PART NO.	DESCRIPTION	ITEM	PART NO.	DESCRIPTION
1.	PB72	Back Door Top Panel	37.	PB92	Hydraulic Motor Mount
2.	PB23	Back Door Top Steel	38.	4C4	13T Sprocket
3.	PB24	Back Door Bottom Steel	39.	PB193	52T Sprocket
4.	S288	Seal Strap	40.	PB95	11T-84T Sprocket
5.	PB54	Rubber Seal	41.	PB114	#80 Chain 73 Pitches
6.	PB74	Drive Shaft Panel	42.	PB97	#50 Chain 90 Pitches
7.	PB80	LH Drive Shaft Mount	43.	PB119	Drive Shaft Brace
8.	PB139	Center Bearing Bracket	44.	17G69	Chain Tightener Bracket
9.	PB82	RH Drive Shaft Mount	45.	23N238	Roller Chain Tightener
10.	S233	667H Pintle Slat with Attachment Links	46.	10R32	Snap Ring
11.	11S51	667H Pintle Connector Links	47.	PB138	Rear Shaft Shield
11A.	11S50	667H Pintle Attachment Links RH or LH	48.	S192	Handle Nuts
12.	S324	667H Complete Pintle Apron 16'	49.	T37	Cotter Pin
*	S325	667H Complete Pintle Apron 18'	50.	PB100	Hinge Pin
*	S326	667H Complete Pintle Apron 20'	51.	23N67	Hose Holder
13.	S60	Idler Shaft Sprockets	52.	PB101	Hydraulic Pipe 16'
14.	PB57	Latch Bracket RH	*	PB18	Hydraulic Pipe 18'
15.	PB58	Latch Bracket LH	*	PB102	Hydraulic Pipe 20'
16.	PB83	Latch Sprocket	53.	PB103	Poly Shield Strap
17.	PB84	Rear Door Lock Latch LH	54.	PB104	Poly Shield
18.	PB85	Rear Door Lock Latch RH	55.	F32	U-Bolt
19.	PB60	Latch Plate	56.	F33	Cable Guide
20.	23N17	Bushing 1-3/4" OD x 1-1/2" ID x 2-1/2"	57.	PB134	Bushing 2-1/2" OD x 2-1/4" ID x 1" Long
21.	PB61	Latch Pivot	58.	PB108	Bushing 1-1/2" OD x 1-1/4" ID x 1-3/4"
22.	PB87	Key 3/8" x 2" Square	59.	A34	Latch Washer
23.	PB133	Key 3/8" x 4-3/8" Square	60.	HE58	Elbow
24.	PB136	Key 3/8" x 2" Square, Hardened w/Round Ends	61.	PB41	Hydraulic Hose 1/2" x 60"
25.	PB194	Drive Shaft	62.	PB105	1/2" Pipe Coupling
26.	PB73	Back Door Framework	63.	DF18	Check Valve
27.	PB65	Hinge	64.	PB118	Rear Clutch Dog
28.	3G22	Expansion Pin	65.	PB191	Clutch Pin
29.	PB66	Guard	66.	PB130	Collar
30.	PB129	Hinge Pin	67.	PB135	Bushing (1)
31.	PB89	Tightener Shafts	68.	23N227	Snap Ring
32.	A7	Idler Bolt 9"	69.	PB126	Clutch Sprocket Washer
33.	DF1	Hydraulic Motor	70.	PB190	Lynch Pin
34.	23N122	Drive Shaft Sprockets	71.	PB196	Lock Tab
35.	PB90	Inside Idler Shaft			
36.	PB91	Hydraulic Motor Mount Spacer			

**NOTE:** \* (Means Not Shown)

FIGURE 7

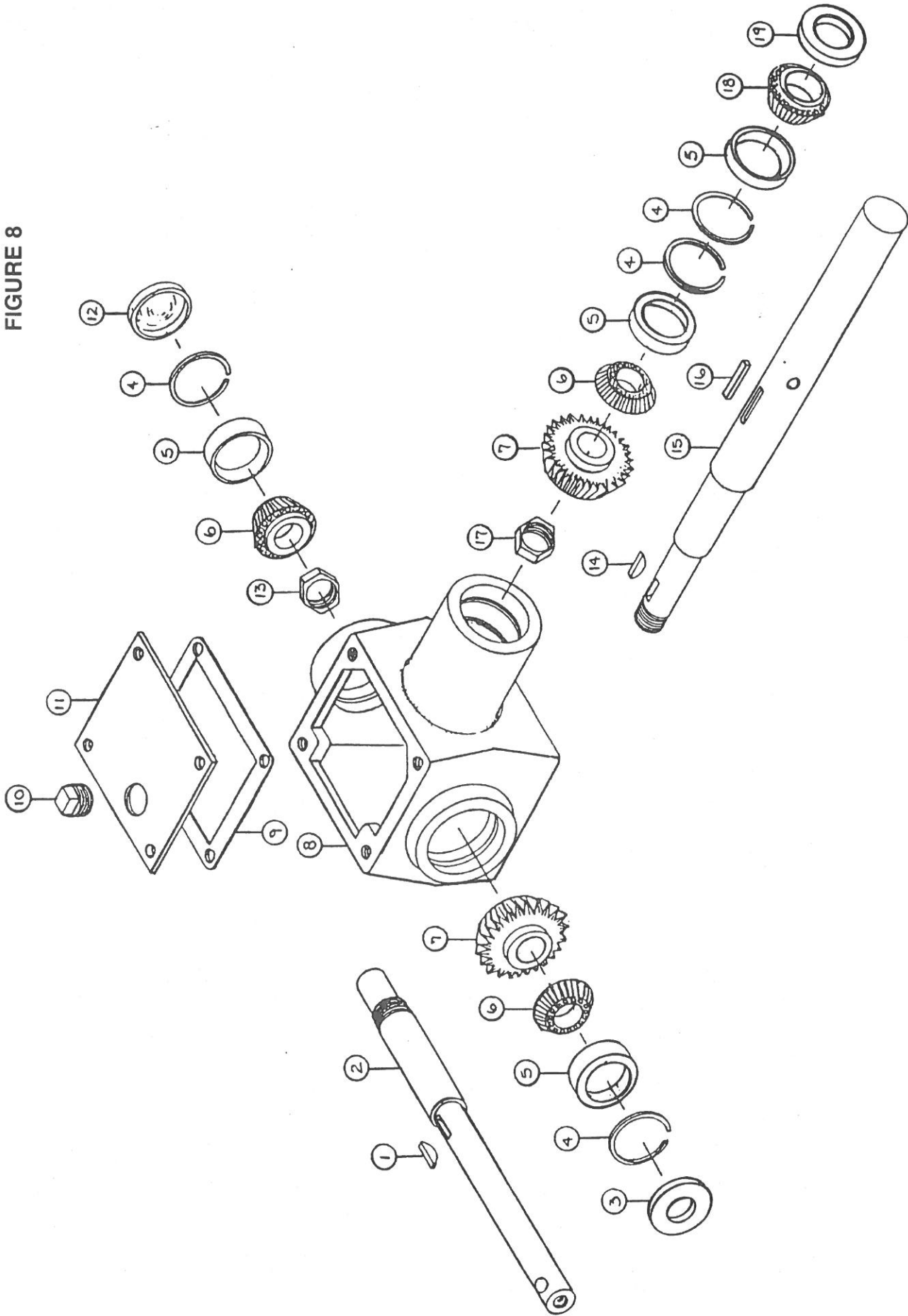

**FIGURE 7  
BOX COMPONENTS**

<b>ITEM</b>	<b>PART NO.</b>	<b>DESCRIPTION</b>
1.	S146	Top Rail 16'
*	S147	Top Rail 18'
*	S297	Top Rail 20'
2.	S143	Top Rail 16'
*	S144	Top Rail 18'
*	S298	Top Rail 20'
3.	S149	16' Side Steel
*	S150	18' Side Steel
*	S299	20' Side Steel
4.	S152	16' Roof Steel
*	S153	18' Roof Steel
*	S300	20' Roof Steel
5.	ST61	Front Branch Guard
6.	ST60	Roof Support
7.	ST49	Side Stake
8.	PB140	LH Rear Stake
9.	PB68	RH Rear Stake
10.	S163	16' Apron Chain Center Spacer
*	S164	18' Apron Chain Center Spacer
*	S301	20' Apron Chain Center Spacer
11.	S166	16' Apron Chain Side Spacer
*	S167	18' Apron Chain Side Spacer
*	S302	20' Apron Chain Side Spacer
12.	S169	16' Floor Assembly
*	S170	18' Floor Assembly
*	S303	20' Floor Assembly
13.	S268	Stake Pockets
14.	ST48	Front Stake
15.	PB106	Brace
16.	PB12	Door Hinge Bracket
17.	ST55	Stake Spacer
18.	ST57	Plastic Grommet for Cable
19.	ST56	Cable Bracket
20.	S236	Rear Roof Support
21.	S399	Rear Branch Guard

**NOTE:** \* (Means Not Shown)

FIGURE 8



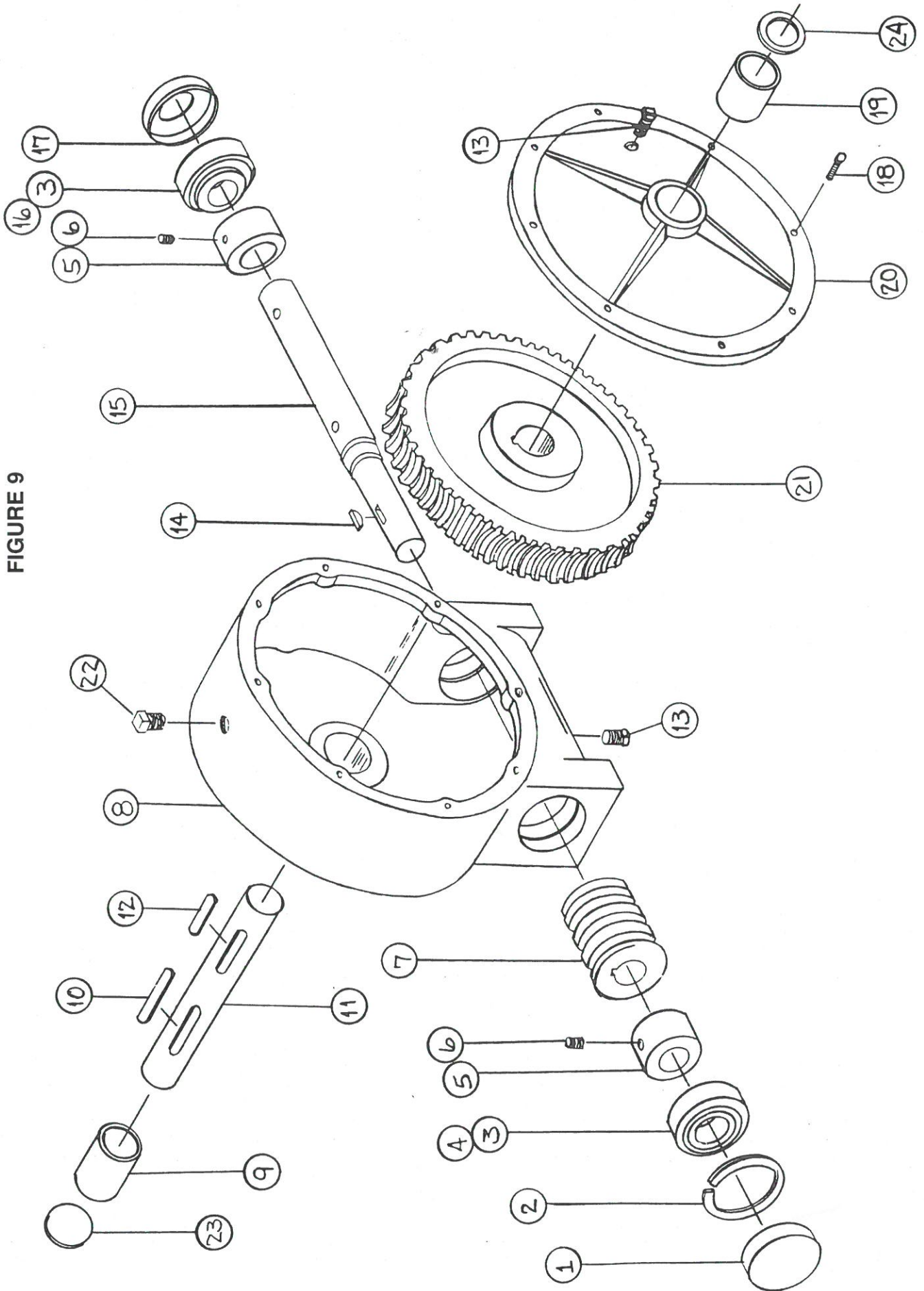

**FIGURE 8  
BEVEL GEARBOX**

<b>ITEM</b>	<b>PART NO.</b>	<b>DESCRIPTION</b>
1.	5B10	1/4" x 1" Woodruff Key
2.	S132	Gearbox Side Shaft
3.	3G9	Seal
4.	3G19	Snap Ring
5.	3G18	Race #15245
6.	3G7	Bearing #15101
7.	3G5	Gear
8.	3G1	Gearbox Housing
9.	3G2	Gearbox Gasket
10.	3G20	Fill Plug
11.	3G3	Cover
12.	X2	Dust Cap
13.	3G11	Nut
14.	5B10	1/4" x 1" Woodruff Key
15.	S134	Gearbox Front Shaft
16.	S135	1/4" x 1-1/4" Square Key
17.	3G4	Nut
18.	L3G24	Gearbox Bearing #15113
19.	S136	Seal
*	S137	Bevel Gearbox Complete

**NOTE:** \* (Means Not Shown)

FIGURE 9



**FIGURE 9  
WORM GEARBOX**

<b>ITEM</b>	<b>PART NO.</b>	<b>DESCRIPTION</b>
1.	G90	Dust Cap
2.	3G19	Snap Ring
3.	3G18	Race #15245
4.	3G7	Bearing #15101
5.	X9	Spacer
6.	G83	Set Screw
7.	G76	Worm
8.	G114	Gearbox Housing
9.	X8	Gearbox Bushing
10.	S138	3/8" x 2-3/8" Square Key w/Round Ends
11.	S139	Worm Gear Side Shaft
12.	A32	3/8" x 1-3/8" Square Key
13.	G65	Plug 3/8"
14.	5B10	1/4" x 1" Woodruff Key
15.	S140	Worm Gear Front Shaft
16.	L3G24	Gearbox Bearing #15113
17.	G115	Seal
18.	G84	Cap Screw
19.	X75	Cover Bushing
20.	G116	Worm Gearbox Cover
21.	G77	Worm Gear
22.	G91	Vent Plug
23.	G117	Cap
24.	G120	Seal 1-7/8"
*	G118	Worm Gearbox Complete

**NOTE:** \* (Means Not Shown)

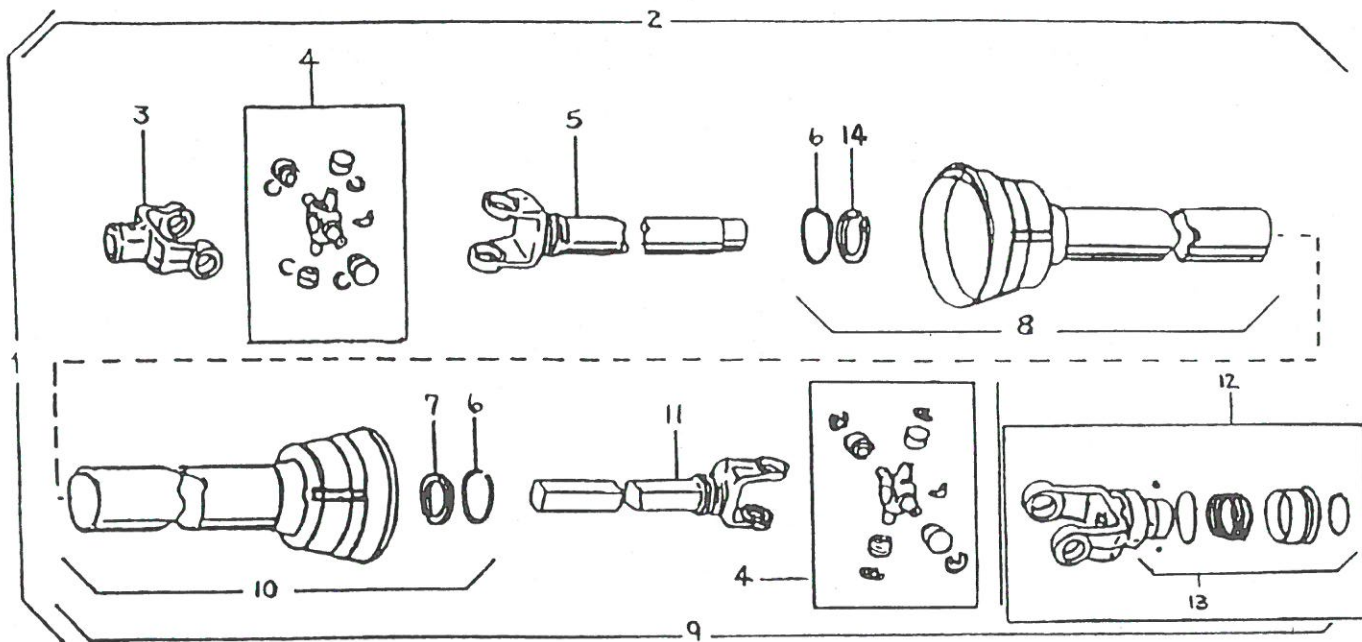

**FIGURE 10**  
**PTO PARTS**  
**HD NEEDLE BEARING PTO**

ITEM	PART NO.	DESCRIPTION
1.	S372	PTO Assembly Complete
2.	S373	Machine Half PTO W/Shield
3.	S374	End Yoke - Machine Half
4.	S375	"W" Repair Kit
5.	S376	Yoke and Tube
6.	24N26	Bearing Retainer
7.	S206	Nylon Bearing
8.	S397	Inner Guard Includes Cent. & Item #6 & #14
9.	S377	Tractor Half PTO
10.	S398	Outer Guard Includes Item #6 & #7
11.	S378	Yoke and Shaft
12.	S379	Lock Yoke - Yoke Assembly
13.	S225	Spring Lock Repair Kit
14.	S396	Nylon Bearing
*	S402	Safety Manual

**NOTE:** \* (Indicates Item Not Shown)

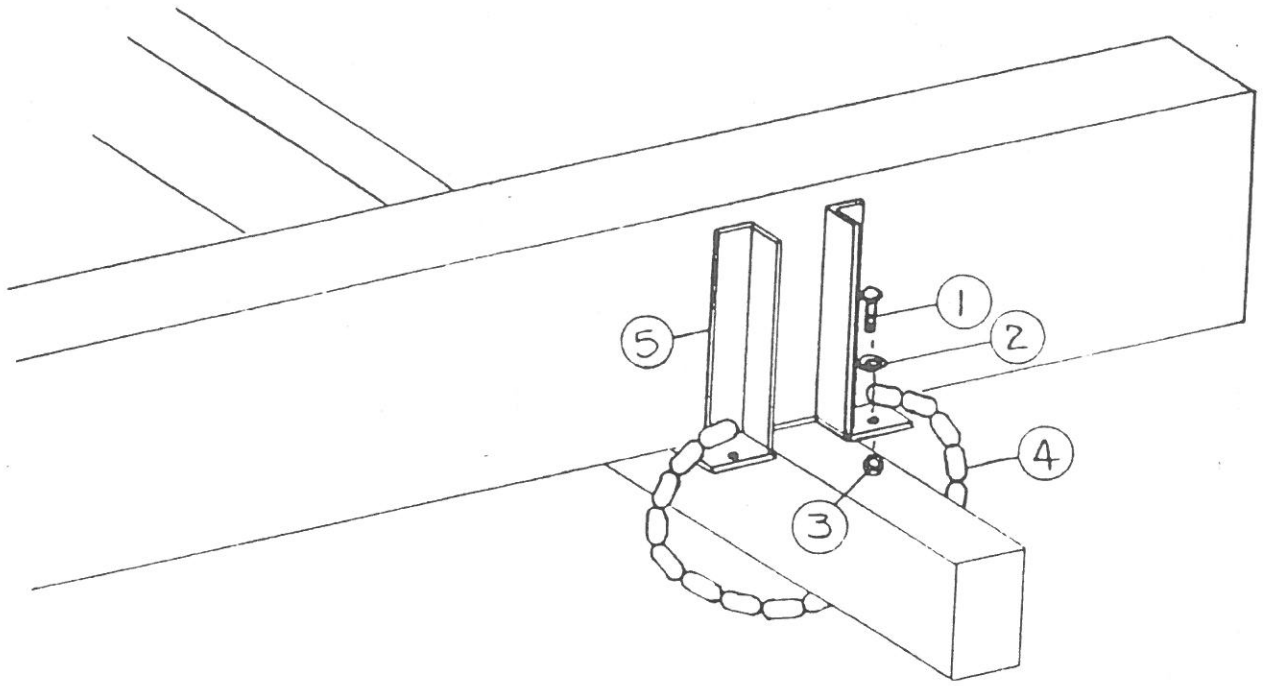
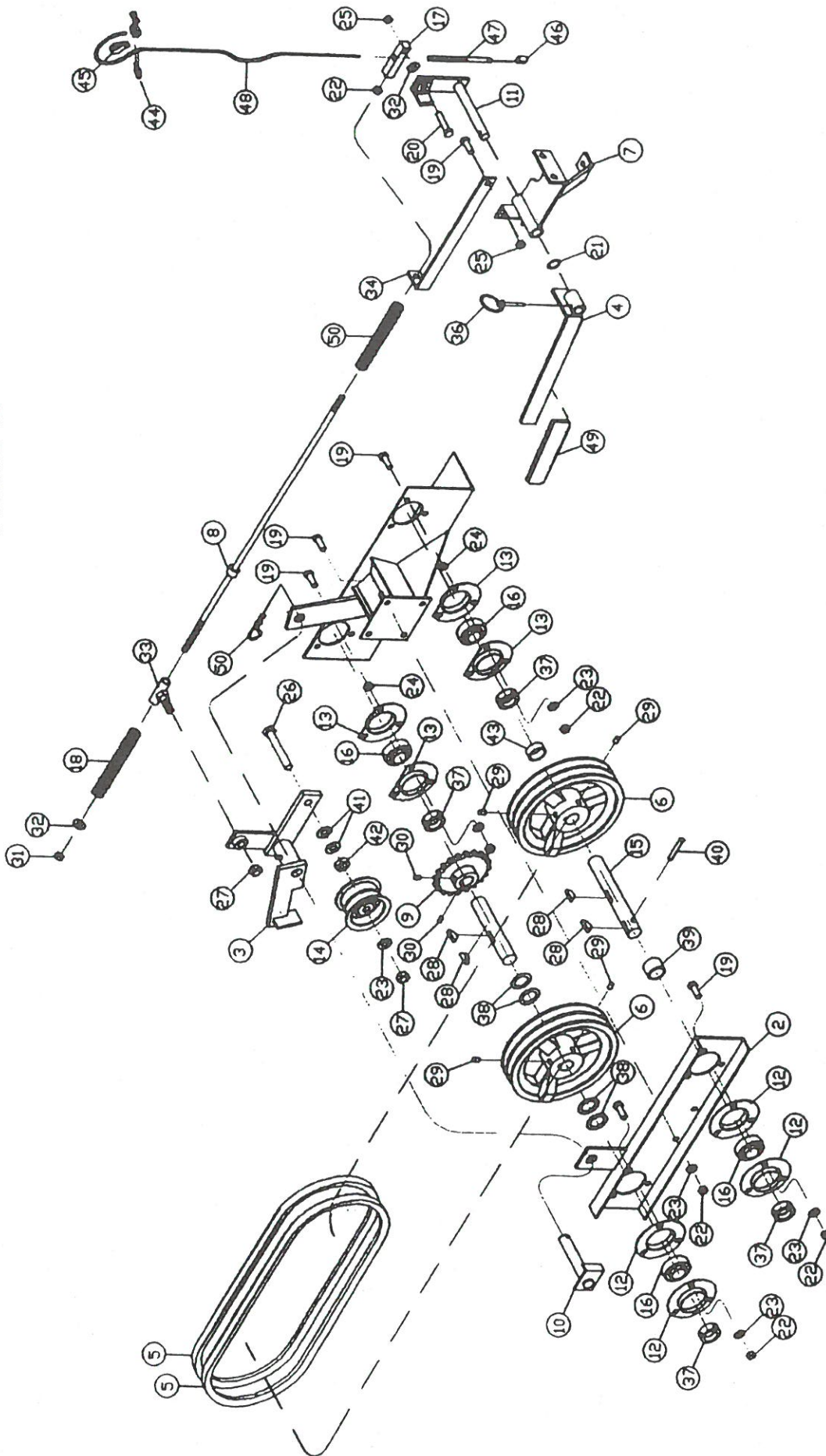

**FIGURE 11  
TIE DOWN KIT**

ITEM	PART NO.	DESCRIPTION
1.	12V45	1/2" x 1-1/2" GR.5 Bolt
2.	K68	1/2" Flat Washer
3.	R11	1/2" Top Lock Nut GR.5
4.	S322	1/4" Chain 30-1/4" Long
5.	S323	Tie Down Bracket
*	T9B	Tie Down Kit (Complete)

**NOTE:** (Means Not Shown)

FIGURE 12



**FIGURE 12**  
**CROSS CONVEYOR CLUTCH - BELT DRIVE**

<b>ITEM</b>	<b>PART NO.</b>	<b>DESCRIPTION</b>
2.	S335	Front Clutch Plate
3.	S341	Idler-Stop Assembly
4.	S337	Handle Lever
5.	S332	Drive Belt
6.	S342	Pulley
7.	S339	Handle Mount
8.	S343	Shifting Rod
9.	11S19	Sprocket 50B20
10.	S340	Tightener Pivot Shaft
11.	S338	Handle Lever
12.	4C7	Bearing Flange
13.	X85	Bearing Flange Sheared
14.	K156	Idler Pulley
15.	S350	Input Pulley Shaft
16.	4C8	Bearing
17.	S347	Shifter Rod End
18.	23N211	Spring 5/8"
19.	X111	3/8" x 1" Bolt GR.5
20.	BFR320	3/8" x 1-3/4" Bolt GR.2
21.	S352	Internal Star Washer
22.	K60	3/8" Nut
23.	B68	3/8" Lockwasher
24.	S355	3/8" Jam Nut
25.	K25	3/8" Locknut
26.	16SV91	1/2" x 3-1/4" Bolt GR.5
27.	R11	1/2" Top Locknut
28.	5B10	1/4" x 1" Woodruff Key
29.	---	3/8" Setscrew
30.	---	5/16" Setscrew
31.	A14	3/8" Nylock Nut
32.	X67	3/8" Flatwasher
33.	S344	Clutch Rod Slide
34.	S348	Spring Bracket
35.	S349	Drive Pulley Shaft
36.	F56	Linch Pin
37.	4C9	Bearing Lock Collar
38.	S345	Spacer (.074)
39.	K99	Spacer, 7/8"
40.	BFR335	5/16" x 2" Expansion Pin
41.	K68	1/2" Lockwasher
42.	X112	Spacer, 9/16"
43.	K106	Spacer, 1/2"
44.	BFR220	Cable Clamp
45.	ES4	Thimble
46.	ES5	Cable Compression Sleeve
47.	S361	Stop Cable Stiffener
48.	S358	Emergency Stop Cable
49.	S362	Handle Lever Grip
50.	S369	Spring, 3/4"

FIGURE 13

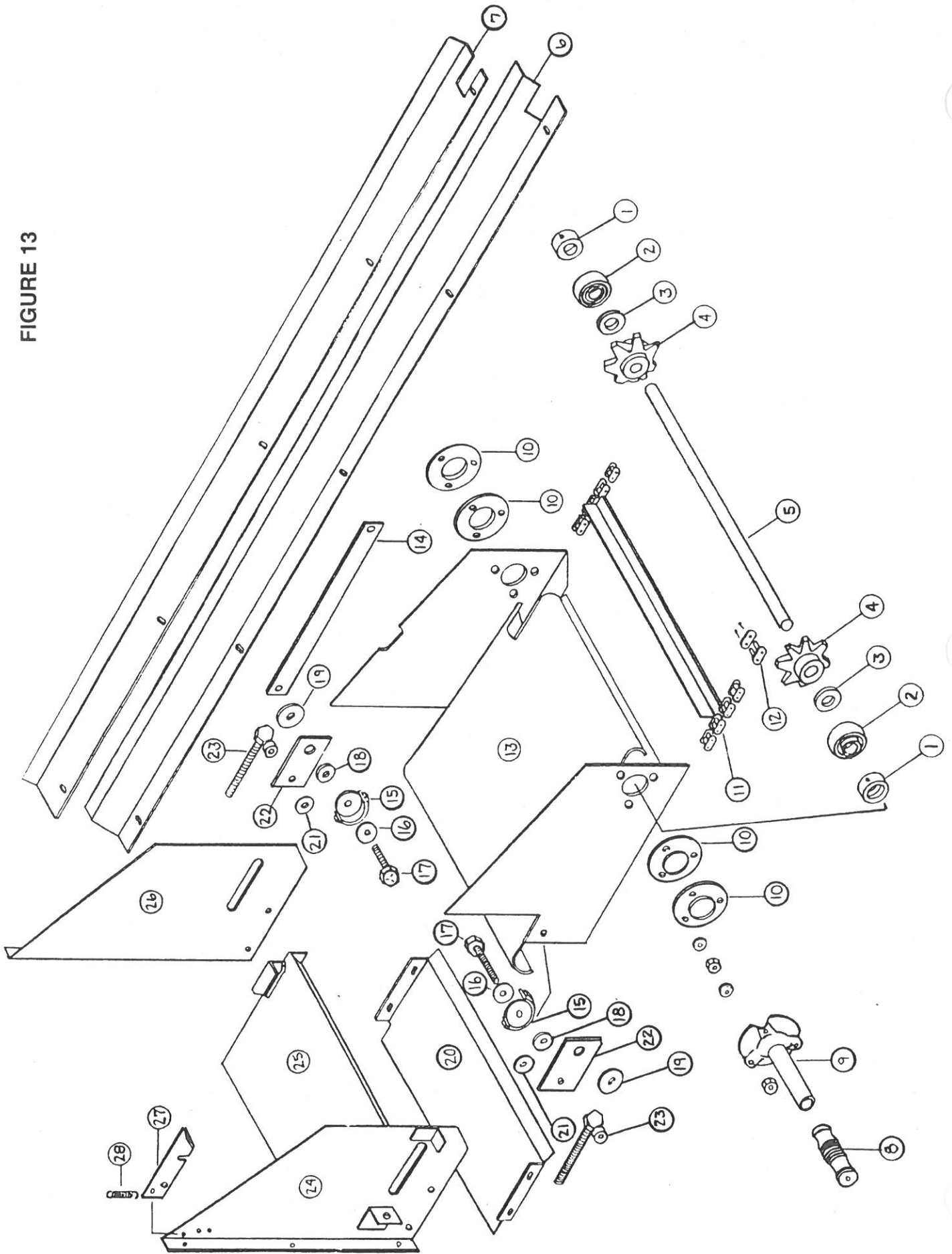



**FIGURE 13**  
**H&S MODELS H D 7+4 & 501 OPTIONAL 12" EXTENSION**

ITEM	UNIT MODEL AND PART NO.		DESCRIPTION
	S7+4	501	
1.	4C9	"	Lock Collar
2.	4C8	"	1" Bearing
3.	BFR33	"	Spacer
4.	S417	"	8T Sprocket
5.	S238	"	Extension Idler Shaft
6.	S239	K196	Cross Conveyor Front Holddown
7.	S240	K197	Cross Conveyor Back Holddown
8.	X41	"	Handle Grip
9.	S241	"	Handle
10.	4C7	"	Bearing Flange
11.	S242	"	Cross Conveyor
12.	K121	"	Connector Link
13.	S243	"	Main Shell
14.	S244	"	Extension Brace
15.	S245	"	Chain Slide Assembly
16.	A34	"	Washer
17.	23N194	"	Bolt, 1/2" x 1-3/4" GR.5
18.	S246	"	Extension Shell Hinge
19.	S247	"	Extension Washer
20.	S248	"	Pan Extension
21.	S249	"	Extension Shell Spacer
22.	S250	"	Extension Side Plates
23.	S251	"	Extension Tightener Bolt
24.	S252	"	Extension Front Panel
25.	S253	"	Extension Slider Pan Assembly
26.	S254	"	Extension Back Panel
27.	S255	"	Extension Latch
28.	12R3	"	Spring

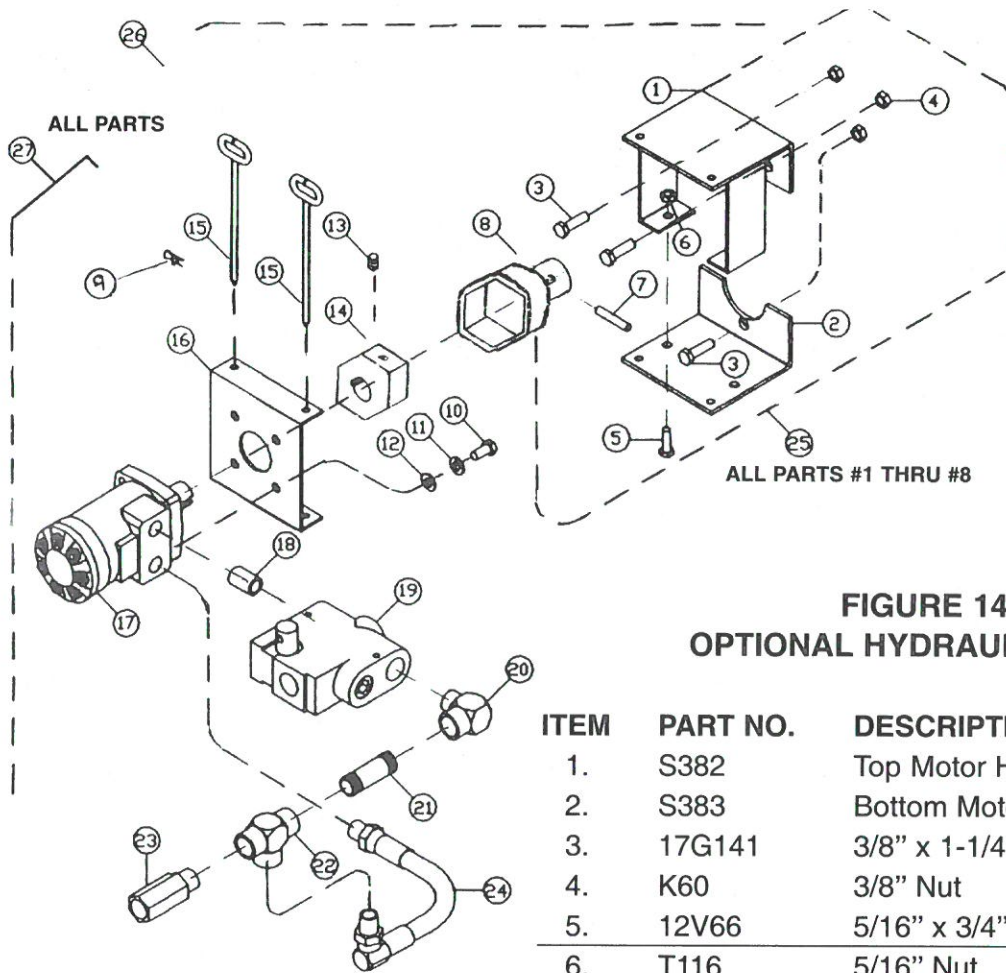

**FIGURE 14**  
**OPTIONAL HYDRAULIC DRIVE**

ITEM	PART NO.	DESCRIPTION
1.	S382	Top Motor Hanger
2.	S383	Bottom Motor Hanger
3.	17G141	3/8" x 1-1/4" Bolt GR.5
4.	K60	3/8" Nut
5.	12V66	5/16" x 3/4" Bolt
6.	T116	5/16" Nut
7.	3G22	5/16" x 1-3/4" Roll Pin
8.	S411	Secondary Drive
9.	X97	Hair Pin
10.	G110	3/8" x 3/4" Bolt
11.	B68	3/8" Lockwasher
12.	X67	3/8" Flat Washer
13.	---	5/16" Set Screw
14.	S410	Primary Drive
15.	S386	Motor Unit Mount Pin
16.	S384	Hydraulic Motor Mount
17.	DF1A	Hydraulic Motor (Super 7+4)
*	ST88	Hydraulic Motor (Twin Auger)
18.	DF7	1/2" Close Nipple
19.	DF15	Flow Control Valve
20.	HE58	1/2" Street Elbow
21.	DF17	1/2" x 2" Pipe Nipple
22.	DF8	1/2" Pipe Tee
23.	DF18	1/2" Check Valve
24.	S395	Hydraulic Hose - 10-1/2"
25.	S388	Extra Unit Drive Kit
26.	S412	Drive Kit (complete Super 7+4)
27.	ST90	Drive Kit (complete - Twin Auger)

## H&S FRONT AND REAR SELF-UNLOADING FORAGE BOX H D 7+4

Your new H&S Forage Box has been manufactured of the finest quality materials and components. The performance you get from your machine is largely dependent upon how well you read and understand this manual and apply this knowledge. There is a right and a wrong way to do everything. Please do not assume that you know how to operate and maintain your Forage Box before reading this manual carefully. Keep this manual available for ready reference.

### H&S H D 7+4 SPECIFICATIONS

Power .....	Tractor PTO or Truck PTO-540 RPM or Hydraulic Drive
Feeder Apron Drive - Front Unload .....	Worm Gear-(Bronze Worm Gear)
Feeder Apron Drive - Rear Unload .....	Roller Chain and Sprocket
PTO Shaft .....	Telescoping Integral Shielded
Speeds - Front Unload .....	Complete Variable Speed
Speeds - Rear Unload .....	Depends on Tractor Hydraulic System
Main Aprons .....	4 Chains-667H Pintle
Beaters .....	3-18" Diameter 4 Spiral Bars
Beater Drive .....	#50 Roller Chain
Emergency Stop Mechanism - Front Unload Only ..	Standard Equipment - All Models
Cross Conveyor .....	#550 Roller Chain w/Angle Cross Slats
Cross Conveyor Drive .....	Sprocket and #50 Roller Chain
Cross Conveyor Width .....	22 Inches
Discharge - Front Unload .....	Left Side Unloading
Inside Length .....	16'-18'-20'
Inside Width .....	7 Feet, 4 Inches
Overall Length .....	20'-2"-22'-2"-24'-2"
Overall Width .....	107"
Overall Height .....	117"

SPECIFICATIONS SUBJECT TO CHANGE WITHOUT NOTICE

#### Warranty

1st Year-Parts & Limited Labor  
2nd Year-Parts

## H&S MANUFACTURING CO. INC.

2608 S. Hume Ave.  
P.O. Box 768 - Telephone (715) 387-3414  
FAX (715) 384-5463  
MARSHFIELD, WI 54449



H&S WAREHOUSE Rt. #5 and 76  
P.O. Box 1260 - Telephone (716) 736-7595  
FAX (716) 736-7596  
RIPLEY, NY 14775

# **H&S MFG. CO.**

products approved

for the

## **FEMA**

# **SEAL OF QUALITY**

